

HISENSE

DECLARATION

We,

Hisense International Co., Ltd
Hisense(Guangdong) Air Conditioner Co., Ltd.
(Supplier Name & Factory Name)

Floor 22, Hisense Tower, 17 Donghai xi Road, qingdao, 266071, China
No.8 Ronggang Road, Ronggui, Shunde,Foshan, Guangdong, P.R.China
No. 8 Hisense Road,Advanced Manufacturing Jiangsha Demonstration Park,529085 Jiangmen,
Guangdong, P.R. China
(Supplier Address & Factory Address)

declare under our sole responsibility that the product

AIR CONDITIONER
(Category Name)

GK 07H-S/GC 07H-S
GK 09H-S/GC 09H-S
GK 12H-S/GC 12H-S
GK 18H-S/GC 18H-S
GK 24H-S/GC 24H-S
GK 30H-S/GC 30H-S
(Model Name)

to which this declaration relates is in conformity with the technical requirements of the following standard(s)

EMC Directive- 2014/30/EU
Low Voltage Directive-2014/35/EU
CE Marking Directive-93/68/EEC

LVD standard
EN 60335-1:2012+A11:2014
EN 60335-2-40:2003
+A11:2004+A12:2005+A1:2006+A2:2009
+A13:2012
EN 62233:2008

EMC standard
EN 55014-1:2006
+A1:2009+A2:2011
EN 55014-2:1997
+A1:2001+A2:2008
EN 61000-3-2:2014
EN 61003-3-3:2013

We, hereby further declare that the following products (Product catalog) are exactly the same, only difference being the art work.

AS-07HR4SYDDJ	GK 07H-S/GC 07H-S
AS-09HR4SYDDJ3	GK 09H-S/GC 09H-S
AS-12HR4SVDDJ1	GK 12H-S/GC 12H-S
AS-18HR4SWADJ	GK 18H-S/GC 18H-S
AS-24HR4SFADJ	GK 24H-S/GC 24H-S
AS-30HR4SQBDJ	GK 30H-S/GC 30H-S

Jason Zhang

Technical Manager

Name of authorized officer

Title of authorized officer

2017-03-12

Date of issue

Signature & company seal

1.Safety Coniderrations

IMPORTANT!

Please Read Before Starting

This air conditioning system meets strict safety and operating standards. As the installer or service person, it is an important part of your job to install or service the system, so it operates safely and efficiently.

For safe installation and trouble-free operation, you must:

- Carefully read this instruction booklet before beginning.
- Follow each installation or repair step exactly as shown.
- Observe all local, state, and national electrical codes.
- Pay close attention to all warning and caution notices given in this manual.



WARNING

This symbol refers to a hazard or unsafe practice which can result in severe personal injury or death.



CAUTION

This symbol refers to a hazard or unsafe practice which can result in personal injury or product or property damage.

If Necessary, Get Help

These instructions are all you need for most installation sites and maintenance conditions. If you require help for a special problem, contact our sales/service outlet or your certified dealer for additional instructions.

In Case of Improper Installation

The manufacturer shall in no way be responsible for improper installation or maintenance service, including failure to follow the instructions in this document.

SPECIAL PRECAUTIONS

When Wiring

WARNING



ELECTRICAL SHOCK CAN CAUSE SEVERE PERSONAL INJURY OR DEATH. ONLY A QUALIFIED, EXPERIENCED ELECTRICIAN SHOULD ATTEMPT TO WIRE THIS SYSTEM.

- Do not supply power to the unit until all wiring and tubing are completed or reconnected and checked.
- Highly dangerous electrical voltages are used in this system. Carefully refer to the wiring diagram and these instructions when wiring. Improper connections and inadequate grounding can cause accidental injury or death.
- Ground the unit following local electrical codes.
- Connect all wiring tightly. Loose wiring may cause overheating at connection points and a possible

fire hazard.

When Transporting

Be careful when picking up and moving the indoor and outdoor units. Get a partner to help, and bend your knees when lifting to reduce strain on your back. Sharp edges or thin aluminum fins on the air conditioner can cut your fingers.

When Installing

● **In a Ceiling or Wall**

Make sure the ceiling/wall is strong enough to hold the unit's weight. It may be necessary to construct a strong wood or metal frame to provide added support.

● **In a Room**

Properly insulate any tubing run inside a room to prevent "sweating" that can cause dripping and water damage to walls and floors.

● **In Moist or Uneven Locations**

Use a raised concrete pad or concrete blocks to provide a solid, level foundation for the outdoor unit. This prevents water damage and abnormal vibration.

● **In an Area with High Winds**

Securely anchor the outdoor unit down with bolts and a metal frame. Provide a suitable air baffle.

● **In a Snowy Area (for Heat Pump-type Systems)**

Install the outdoor unit on a raised platform that is higher than drifting snow. Provide snow vents.

When Connecting Refrigerant Tubing

△ Use the flare method for connecting tubing.

△ Apply refrigerant lubricant to the matching surfaces of the flare and union tubes before connecting them, then tighten the nut with a torque wrench for a leak free connection.

△ Check carefully for leaks before starting the test run.

When Servicing

△ Turn the power OFF at the main power box (mains) before opening the unit to check or repair electrical parts and wiring.

△ Keep your fingers and clothing away from any moving parts.

△ Clean up the site after you finish, remembering to check that no metal scraps or bits of wiring have been left inside the unit being serviced.

Others



△ Ventilate any enclosed areas when installing or testing the refrigeration system. Escaped refrigerant gas, on contact with fire or heat, can produce dangerously toxic gas.

△ Confirm upon completing installation that no refrigerant gas is leaking. If escaped gas comes in contact with a stove, gas water heater, electric room heater or other heat source, it can produce dangerously toxic gas.

NOTE:

The figure, size and parameter of the product may not be identical with the service manual, please take the actual product as the standard.

3.Product Drawing

Indoor 7.9.12.18.24K

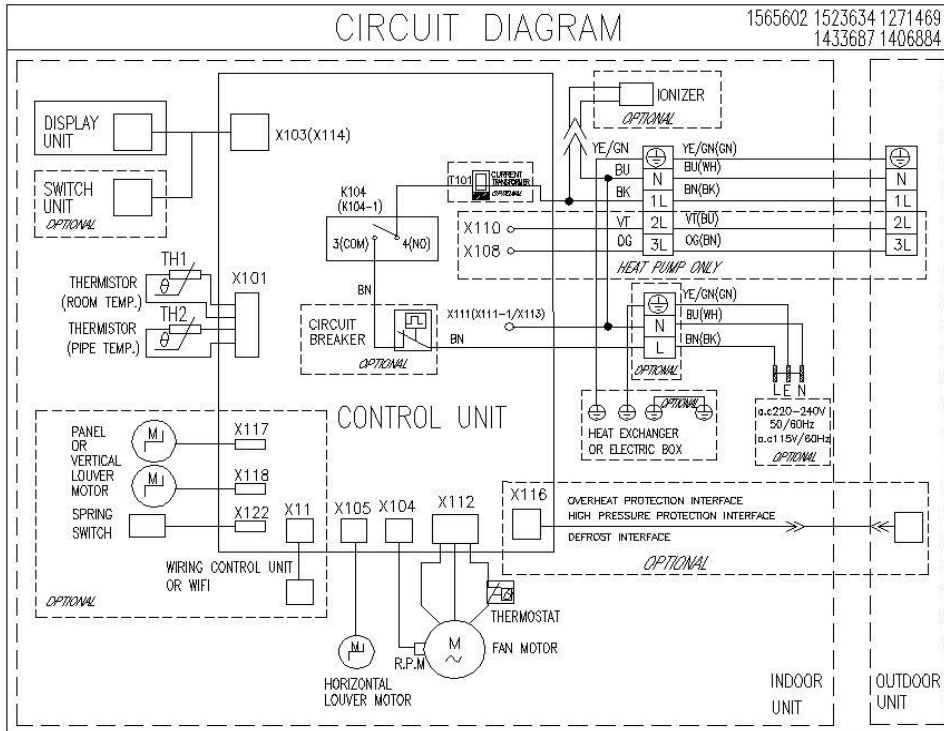

Indoor 30K

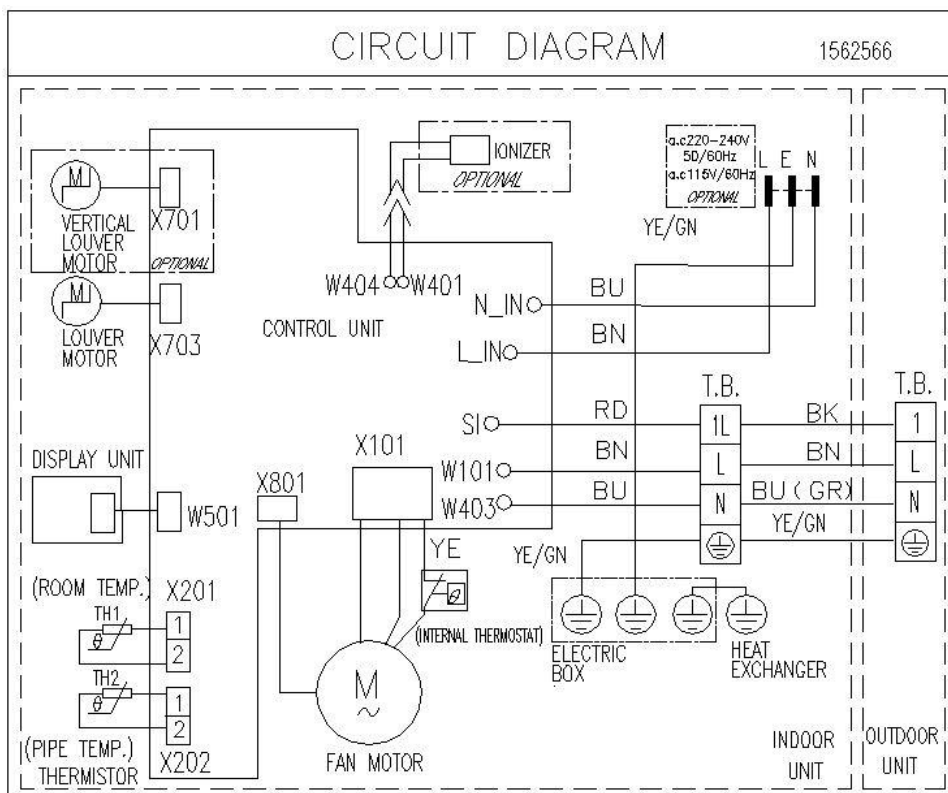

Outdoor 7.9.12.18.24K

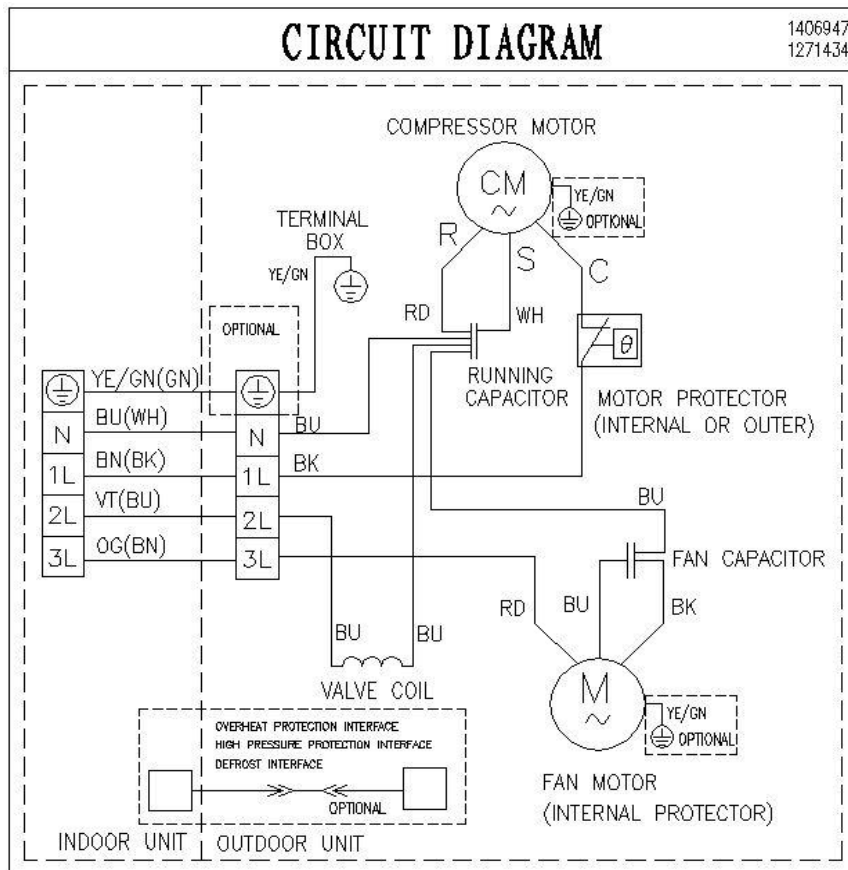

Outdoor 30K

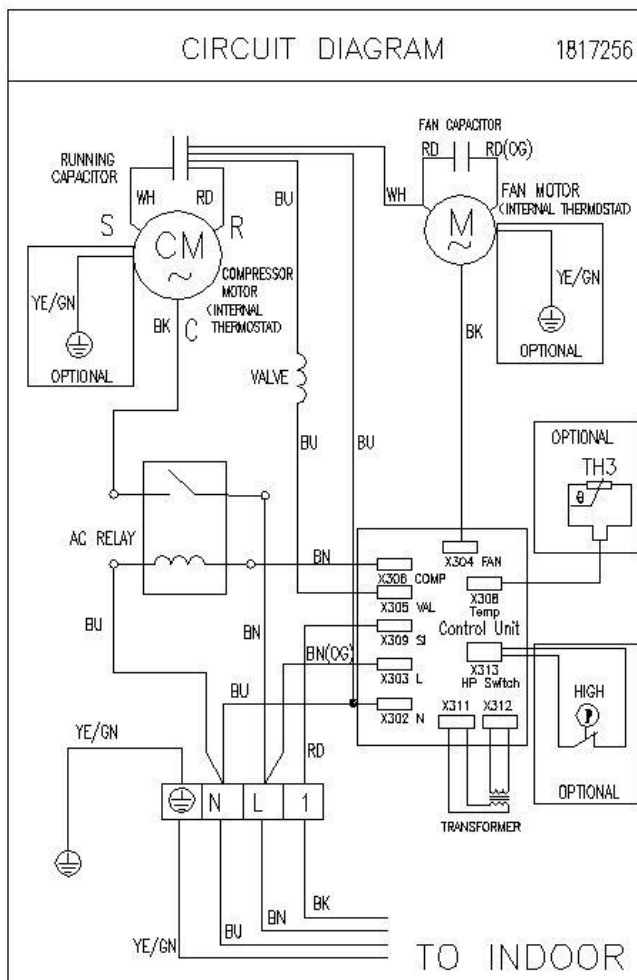

4. Installation Instruction



WARNING

To prevent abnormal heat generation and the possibility of fire, do not place obstacles, enclosures and grilles in front of or surrounding the air conditioner in a way that may block air flow. And, more than 1 meter away from any antenna or power lines or connecting wires used for TV, radio, telephone, security system, or intercom. Electrical noise from any of these sources may affect operation.

4-1. Installation Place and Condition

Indoor unit

Avoid:

- △ direct sunlight.
- △ nearby heat sources that may affect performance of the unit.
- △ areas where leakage of flammable gas may be expected.
- △ places where large amounts of oil mist exist.

Do:

- △ Select an appropriate position from which every corner of the room can be uniformly cooled.
- △ Select a location that will hold the weight of the unit.
- △ Select a location where tubing and drain hose have the shortest run to the outside. (See a)
- △ Allow room for operation and maintenance as well as unrestricted air flow around the unit. (See b)
- △ Install the unit within the maximum elevation difference (H) above or below the outdoor unit and within a total tubing length (L) from the outdoor unit as detailed (See table 1 and c)

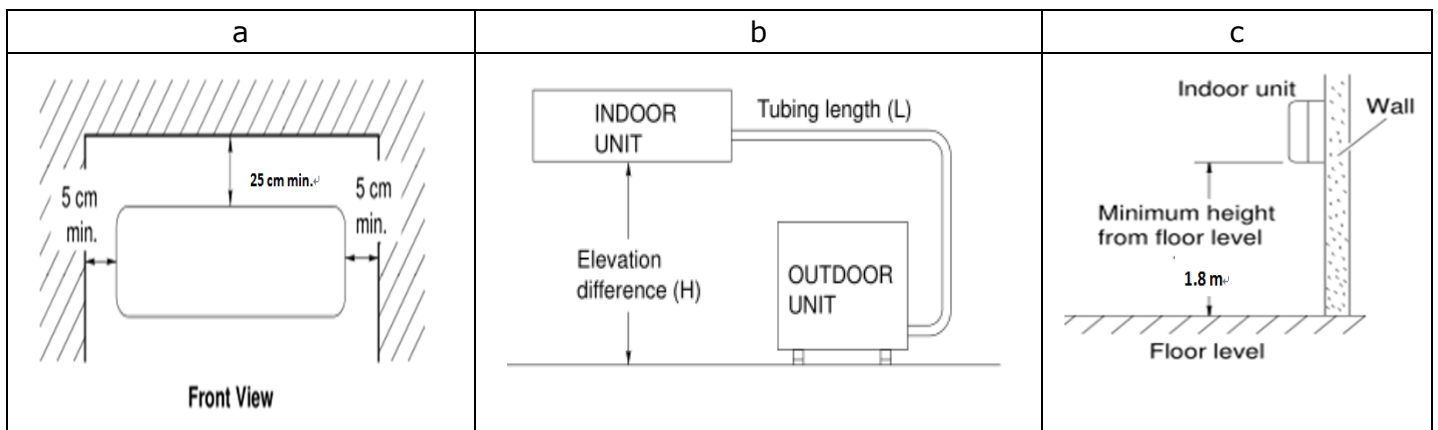

table 1

Capacity	Pipe Size	Standard	Max.	Max.	Additional
----------	-----------	----------	------	------	------------

(Btu/h)	GAS	LIQUID	Length (m)	Elevation B (m)	Length A (m)	Refrigerant (g/m)
5k~14k	3/8"(Ø9.52)	1/4"(Ø6.35)	7.5	7	15	20
	1/2"(Ø12.7)	1/4"(Ø6.35)	7.5	7	15	20
18k~28k	1/2"(Ø12.7)	1/4"(Ø6.35)	7.5	15	30	20
	5/8"(Ø15.88)	1/4"(Ø6.35)	7.5	15	30	20
30k~38k	5/8"(Ø15.88)	3/8"(Ø9.52)	7.5	15	30	30
	3/4"(Ø19.05)	3/8"(Ø9.52)	7.5	15	30	50

* If total tubing length becomes 7.5 to 15 m (max.), charge additional refrigerant as the table1 for reference. And no additional compressor oil is necessary.

Outdoor unit

Avoid:

- △ Heat sources, exhaust fans, etc.
- △ Damp, humid or uneven locations.

DO:

- △ Choose a place as cool as possible.
- △ Choose a place that is well ventilated.
- △ Allow enough room around the unit for air intake or exhaust and possible maintenance. (see a1, b1 & c1)
- △ Provide a solid base (level concrete pad, concrete block, 10 × 40 cm beams or equal), a minimum of 10 cm above ground level to reduce humidity and protect the unit against possible water damage and decreased service life.
- △ Install cushion rubber under unit's feet to reduce vibration and noise.
- △ Use lug bolts or equal to bolt down unit, reducing vibration and noise.

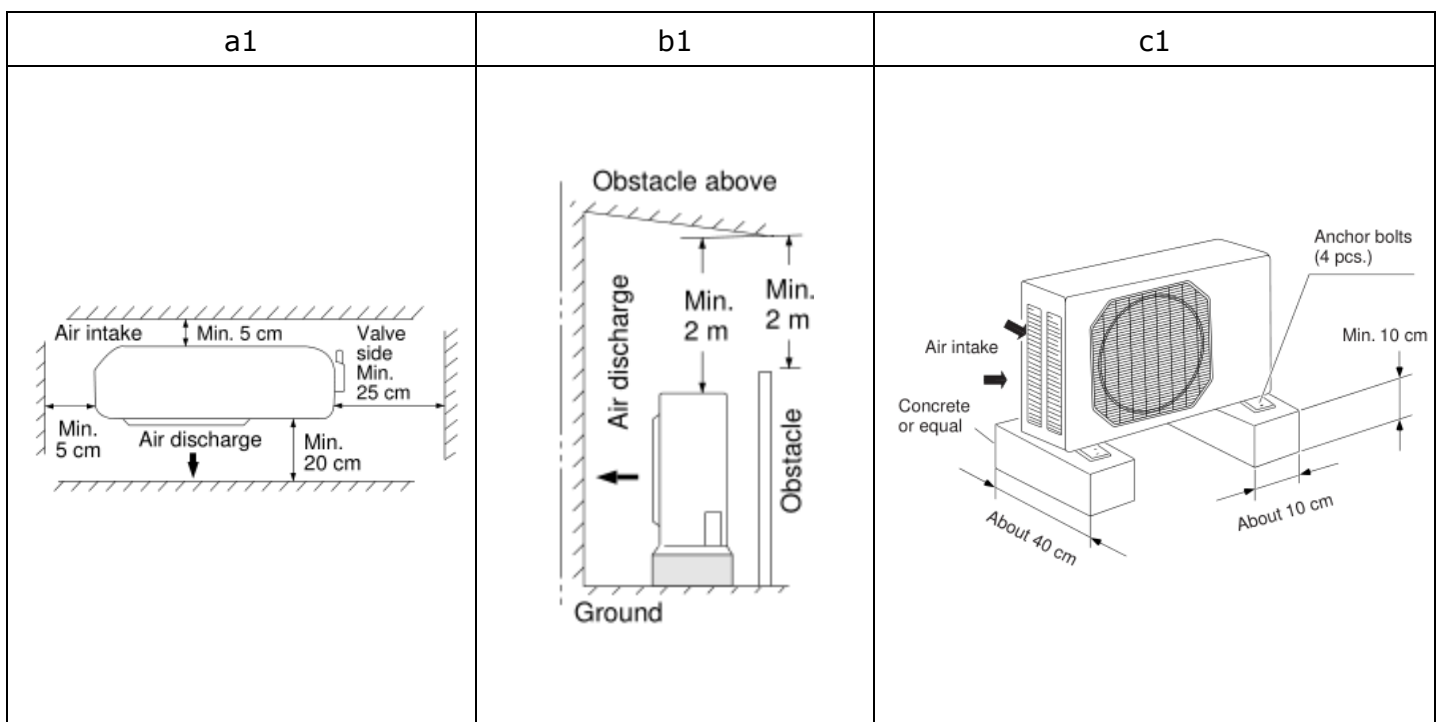

Recommended Wire Diameter:

Capacity (Btu/h)	Power cord		Power connecting cord		Power connecting cord1		Main power supply
	Type	Normal cross - sectional area	Type	Normal cross - sectional area	Type	Normal cross - sectional area	
5K~13K	H05VV-F	1.0~1.5mm ² X3	H07RN-F H05RN-F	1.5mm ² X3 1.0mm ² X3	H05RN-F	0.75mm ² X2 (Heat-pump)	To indoor
14K~24K	H05VV-F	1.5~2.5mm ² X3	H07RN-F	1.5-2.5mm ² X3	H05RN-F	0.75mm ² X2 (Heat-pump)	To indoor
18K~30K	H05VV-F	1.5-2.5mm ² X3	H07RN-F	1.5-2.5mm ² X4	H05RN-F	0.75mm ² X2 (Heat-pump&Optional)	To indoor
18K~30K	H07RN-F	2.5mm ² X3	H05RN-F H07RN-F	1.0mm ² X3 1.0mm ² X4Cooling only	H05RN-F	0.75mm ² X3 (Heat-pump)	To outdoor
24K~36K	H07RN-F	2.5~4.0mm ² X3	H05RN-F H07RN-F	0.75mm ² X4 1.0mm ² X4	H05RN-F	0.75mm ² X2 (Heat-pump&Optional)	To outdoor
24K~36K	H07RN-F	1.5mm ² X5	H05RN-F H07RN-F	0.75mm ² X4 1.0mm ² X4	H05RN-F	0.75mm ² X2 (Heat-pump&Optional)	To outdoor

The cord may be different from the list above. It may be used as the next list. And it can be larger.

0-7A, use 0.75mm² or 18AWG. 0-10A, use 1mm² or 16AWG. 0-16A, use 1.5mm² or 14AWG.

0-20A, use 2.5mm² or 14AWG. 0-25A, use 2.5mm² or 12AWG. 0-32A, use 4mm² or 12AWG.

4-1. Refrigerant Flow System

(1) Cooling

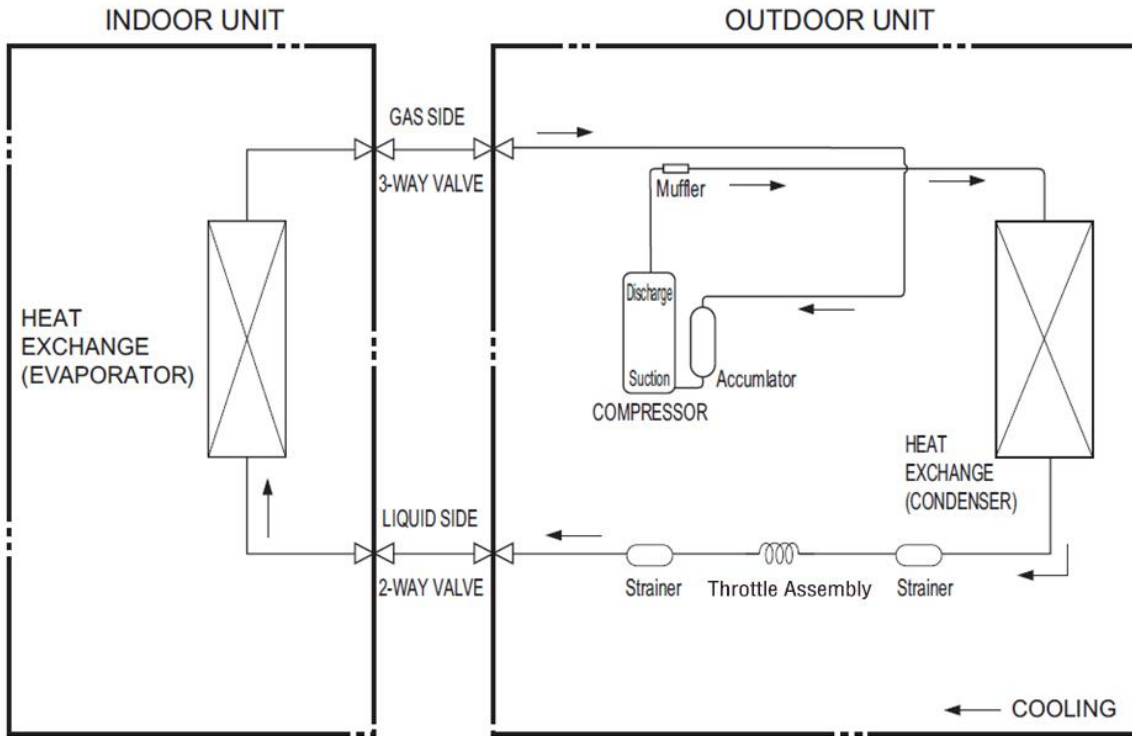

(2) Cooling&Heating

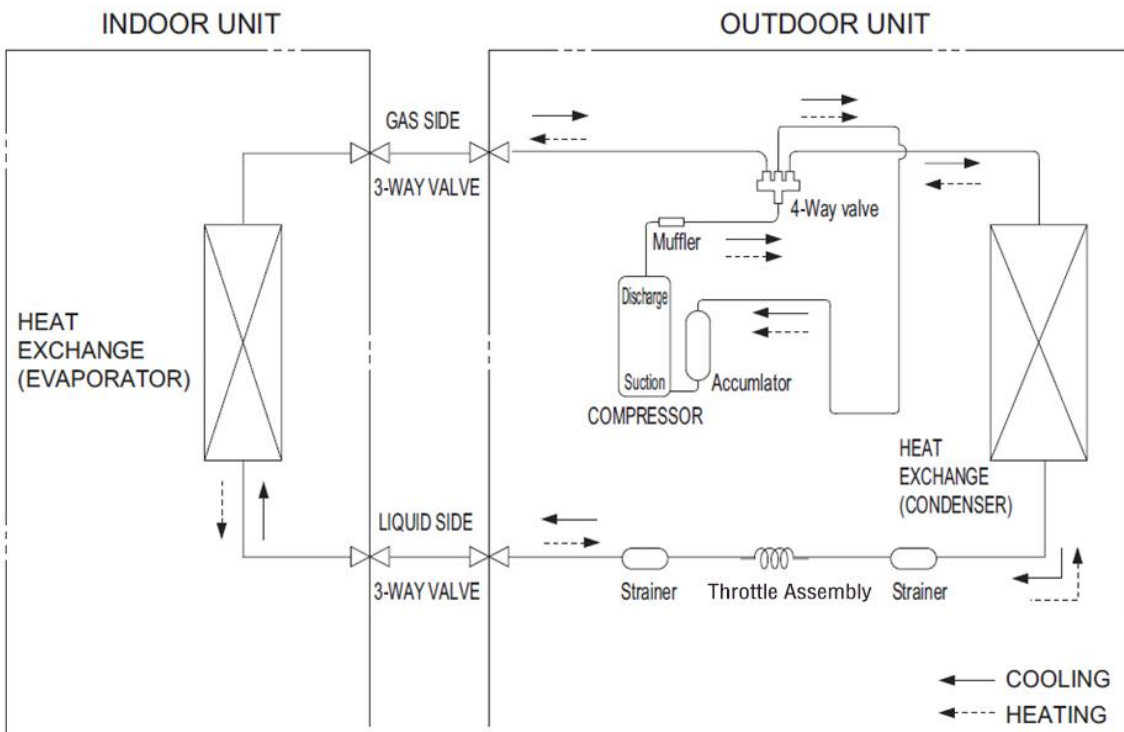

NOTE: In different models, the throttle assembly may be Capillary or Electronic expansion valve.

4-2. Air Purging and Leakage Test

1. Connect charging hose of manifold valve to charge end of low pressure valve (both high/low pressure valves must be tightly shut).
2. Connect joint of charging hose to vacuum pump.
3. Fully open the handle of Lo manifold valve.
4. Open the vacuum pump to evacuate. At the beginning, slightly loosen joint nut of low pressure valve to check if there is air coming inside. (If noise of vacuum pump has been changed, the reading of multimeter is 0) Then tighten the nut.
5. Keep evacuating for more than 15mins and make sure the reading of multi-meter is -1.0×10^5 pa (-76cmHg).
6. Check the vacuum with the gage manifold valve, then close the gage manifold valve, and stop the vacuum pump.
7. Leave it for one or two minutes. Make sure the pointer of the gage manifold valve remains in the same position.
8. Remove the gage manifold valve quickly from the service port of the stop valve. After refrigerant pipes are connected and evacuated, fully open all stop valves on gas and liquid pipe sides.
9. Opening without fully opening lowers the performance and cause dangerous.
10. Tighten the cap to the service port to obtain the initial status.
11. Retighten the cap
12. Leak test

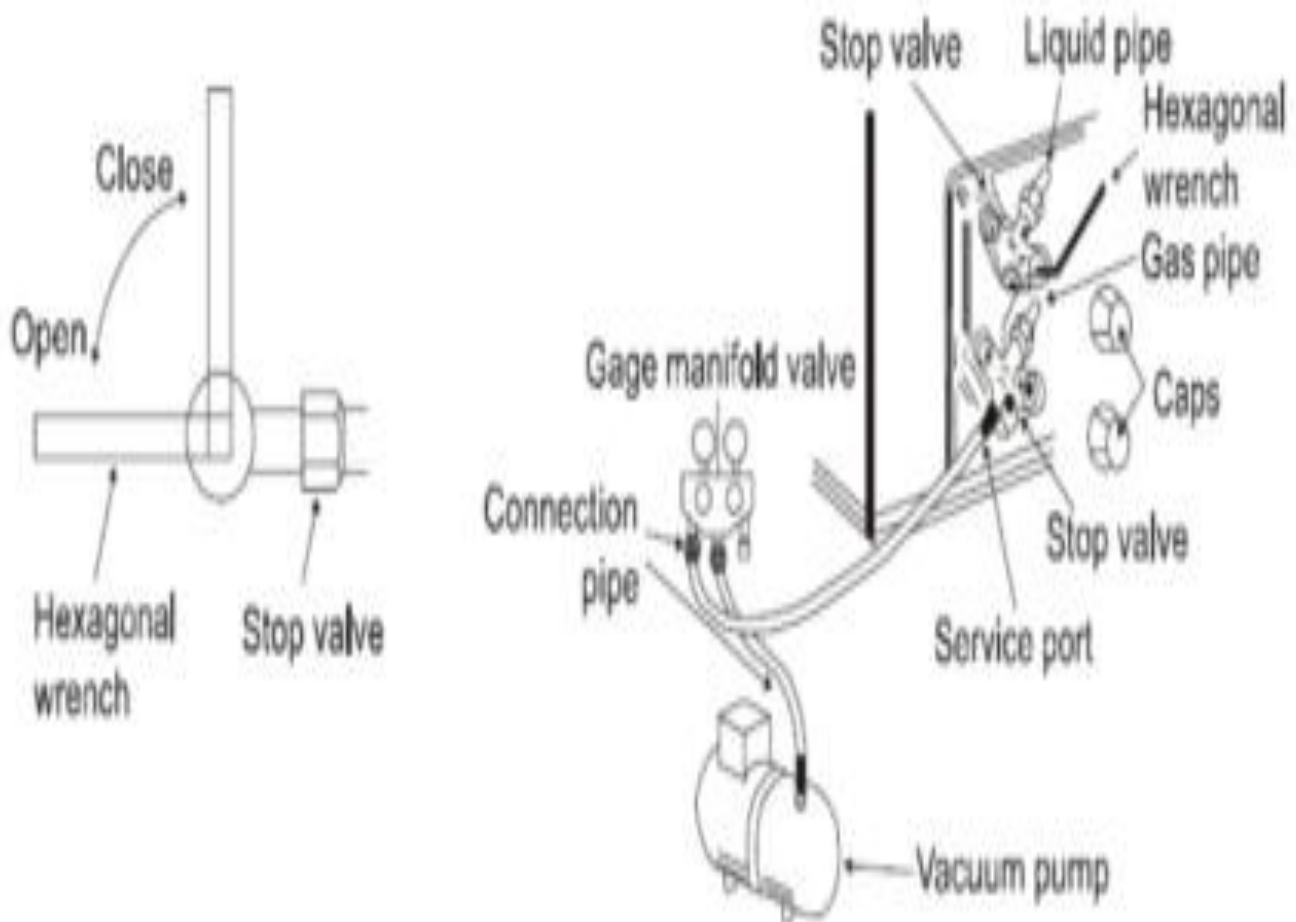

4-3. Test Running

△ Check after Installation

Items to be checked	Possible malfunction
Has it been fixed firmly?	The unit may drop, shake or emit noise.
Have you done the refrigerant leakage test?	It may cause insufficient cooling(heating)capacity
Is heat insulation sufficient?	It may cause condensation and dripping.
Is water drainage satisfactory?	It may cause condensation and dripping.
Is the voltage in accordance with the rated voltage marked on the nameplate?	It may cause electric malfunction or damage the product.
Is the electric wiring and piping connection installed correctly and securely?	It may cause electric malfunction or damage the part.
Has the unit been connected to a secure earth connection?	It may cause electrical leakage.
Is the power cord specified?	It may cause electric malfunction or damage the part.
Are the inlet and outlet openings blocked?	It may cause insufficient cooling(heating)capacity.
Is the length of connection pipes and refrigerant capacity been recorded?	The refrigerant capacity is not accurate.

△Operation Test

1. Before Operation Test

- (1)Do not switch on power before installation is finished completely.
- (2)Electric wiring must be connected correctly and securely.
- (3)Cut-off valves of the connection pipes should be opened.
- (4)All the impurities such as scraps and thrums must be cleared from the unit.

2. Operation Test Method

- (1)Switch on power and press "ON/OFF" button on the remote controller to start the operation.
- (2)Press MODE button to select the COOL, HEAT (Cooling only unit is not available), FAN to check whether the operation is normal or not.

5. Function Operation

5-1. Operation Range (cooling and heating)

Argentina Model :

	Temperature	Indoor Air Intake Temp.	Outdoor Air Intake Temp
COOLING	Maximum	30	43 °C
	Minimum	16°C	16°C
HEATING	Maximum	30°C	24°C
	Minimum	/	-10°C

Mexico Model :

	Temperature	Indoor Air Intake Temp.	Outdoor Air Intake Temp
COOLING	Maximum	30	46 °C
	Minimum	16°C	16°C
HEATING	Maximum	30°C	24°C
	Minimum	/	-10°C

5-2. Remote Controller Operation & Function

△Remote Controller Instruction

Remote controller

The remote controller transmits signals to the system.

SMART (invalid for multi system)

Used to enter fuzzy logic operation directly, regardless of the unit is on or off.

POWER

The appliance will be started when it is energized or will be stopped when it is in operation, if you press this button.

SUPER

Used to start or stop the fast cooling/heating. (Fast cooling operates at high fan speed with 16°C set temp automatically; Fast heating operates at auto fan speed with 30°C set temp automatically)

IFEEL

Used to set IFEEL Mode operation, press the I FEEL button for about 5 seconds, the transmit signal in the display will disappear, the I FEEL function will be shutted off.

SWING

Used to stop or start vertical adjustment louver swinging and set the desired up/down airflow direction.

8° HEAT (optional)

Used to set 8° HEAT Mode.

QUIET

Used to set or cancel Quiet Mode operation.

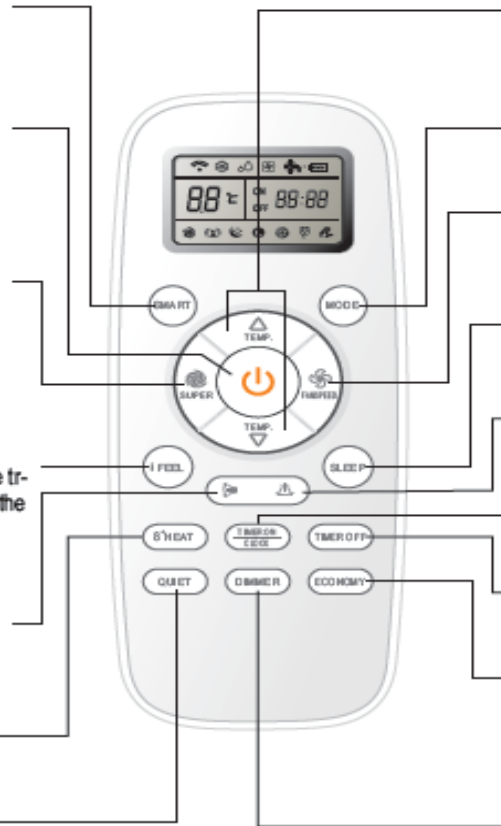

TEMP + -

Used to adjust the room temperature and the timer, also real time.

MODE

Press this button to select the operation mode.

FAN

Used to select fan speed in sequence auto, higher, high, medium, low and lower.

SLEEP

Used to set or cancel Sleep Mode operation.

SWING

Used to stop or start Horizontal adjustment louver swinging and set the desired left/right airflow direction.

TIMER ON/CLOCK

Used to set or cancel the timer operation and used to set the current time.

TIMER OFF

Used to set or cancel the timer operation.

ECONOMY

Used to set or cancel Economy Mode operation.

DIMMER

When you press this button, all the display of indoor unit will be closed. Press any button to resume display.

Indication symbols on LCD:

Cooling indicator	Dry indicator	Fan only indicator	8° Heating indicator	Heating indicator
Auto fan speed	Higher fan speed	High fan speed	Medium fan speed	Low fan speed
Lower fan speed	Sleep 1 indicator	Sleep 2 indicator	Sleep 3 indicator	Sleep 4 indicator
Smart indicator	Quiet indicator	Economy indicator	Super indicator	ON 88:88 Display set timer
Signal transmit	Ifeel	88°C Display set temperature		OFF 88:88 Display current time
				Battery power indicator

Note: Each mode and relevant function will be further specified in following pages.

Remote controller

The remote controller transmits signals to the system.

- 1 ON/OFF BUTTON**
The appliance will be started when it is energized or will be stopped when it is in operation, if you press this button.
- 2 MODE BUTTON**
Press this button to select the operation mode.
- 3 FAN BUTTON**
Used to select fan speed in sequence auto, high, medium or low.
- 4 5 ROOM TEMPERATURE SETTING BUTTONS**
Used to adjust the room temperature and the timer, also real time.
- 6 SMART BUTTON**
Used to enter fuzzy logic operation directly, regardless of the unit is on or off.
- 7 SWING BUTTON**
Used to stop or start vertical adjustment louver swinging and set the desired up/down airflow direction.
- 8 SLEEP BUTTON**
Used to set or cancel Sleep Mode operation.
- 9 IFEEL BUTTON**
Used to set IFEEL mode operation. Press it once, the IFEEL function will be started. Press it again, the IFEEL function will be shut off. If the IFEEL function can't be shut off, please try to press this button about 5 seconds. Advice to put the remote controller in the place where the indoor unit receive signal easily. Advice to cancel the IFEEL mode so as to save energy when stopping the air conditioner.
- 10 CLOCK BUTTON**
Used to set the current time.
- 11 12 TIMER ON/OFF BUTTON**
Used to set or cancel the timer operation.

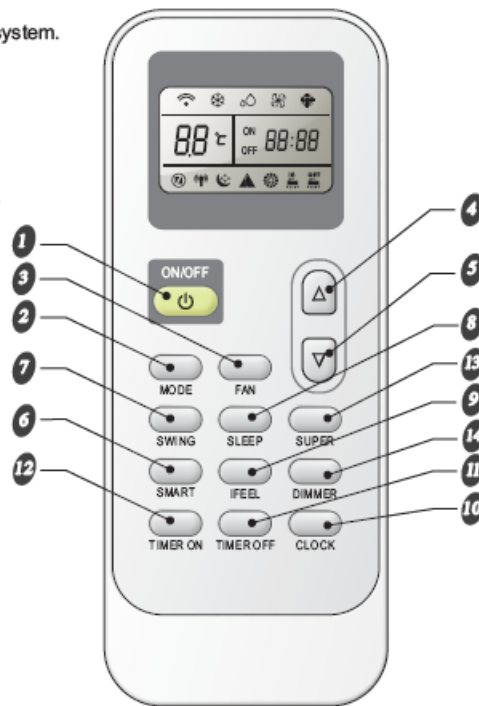

- 13 SUPER BUTTON**
Used to start or stop the fast cooling/heating. (Fast cooling operates at high fan speed with 18°C set temp automatically ; Fast heating operates at auto fan speed with 32°C set temp automatically)
- 14 DIMMER BUTTON**
When you press this button, all the display of indoor unit will be closed. Press any button to resume display.

Indication symbols on LCD:

Cooling indicator	Auto fan speed	Smart indicator	Signal transmit
Dry indicator	High fan speed	Sleep indicator	ON 88:88 Display set timer
Fan only indicator	Medium fan speed	Ifeel	OFF 88:88 Display current time
Heating indicator	Low fan speed	Super indicator	88°C Display temperature

Note: Each mode and relevant function will be further specified in following pages.

△Function Instruction

1. Major general technical parameters

- 1-1 Remote receiver distance (front of the air conditioner) : 8 m.
- 1-2 Remote receiver angle: Less than 60 degrees.
- 1-3 Temperature control accuracy: $\pm 1^{\circ}\text{C}$.
- 1-4 Time error: Less than 1%.

2. Functions of the controller

2-1 Display panel

- I. Control functions of the remote controller (See operating and installation manual)
- II. Display of the indoor unit

Information on the screen:

Displaying Scheme:

7-segment tube: Display set temperature or indoor temperature , and display fault code in trouble indicating. An error code is displayed according to the signal from the indoor CPU. The error code will

flash for 5 seconds while displayed.

Running LED: It is on during operation. It is flashing when the unit defrost.

TIMER LED: When the timer mode works, the LED will be lighted.

Sleep LED: When the sleep mode works, the LED will be lighted, and after 10s, the LED will be off.

Compressor LED: It lights up when compressor is running.

Remote control receiver: This section receives signals from the remote control.

3. Control function

3-1 Emergency switch

If the appliance under the Stand-by state, all the Operation Mode, Air volume, Temperature Setting , Forced Cooling function will be restored as the last time setting when you press on the "ON/OFF" button, but lost the Air flow direction setting.

If the appliance was connected to the power at first time, it would operate in the auto mode, It will keep in stand-by state if you press the "ON/OFF" button during the normal operation.

When the appliance under the Stand-by state, press and hold the emergency switch for 5 seconds, the buzzer rings for 1 times, and it will operate in cooling mode, and the indoor fan speed is set to high-speed, it running has nothing to do with the room temperature.

When press the emergency switch or receive the signal of the remote control, it will exit this mode, and it will operate with the corresponding order.

3-2 Operator-machine communication

If the unit has I feel function, when the I feel function is set by the remote control, the room temperature will depend on the remote control and it will be detected by the sensor of the remote control. Normally the remote control will automatically transmits a signal at an interval of 10 minutes (only for H1 remote control, it is 9 minutes) , but if the room temperature changed exceed 1°C in a short period of time, the remote control will transmits a signal within 2 minutes. If the indoor unit has not received a remote signal within 30 minutes, the room temperature will depend on the room temperature sensor of indoor unit.

3-3 Timer function

Real time of Timer setting

(1) The max Timer ranges is 24 hours.

(2) Timer ON/OFF

(3) Timer ON/OFF can be set available in turn.

(4) The Timer accurate more than 97%

(5) The Timer can be adjusted by 1 min increase.

(6) The appliance can be set the ON-Timer and OFF-Timer in the same time, but no any timer setting indicated.

3-4 Sleep

(1)The Sleep mode can only be set during Cool, Heat and Dry mode.

(2) When the appliance run in the Sleep mode, it will stop after 8 hours operation, then it will cancel the Sleep setting. When the appliance operate under the OFF-Timer setting condition, if the

OFF-Timer setting less than 8 hours, it will keep the Sleep mode till the OFF-Timer setting; if the OFF-Timer setting more than 8 hours, it will cancel the OFF-Timer setting after the Sleep mode OFF.

(3) When the Sleep mode is select with Cooling mode, if the room temperature not less than 26°C, the setting temperature will not be adjusted, otherwise, the setting temperature will be raised by 1°C per hour, but the max setting temperature raise is 1°C.

(4) When the Sleep mode is select with Heat mode, the setting temperature will be decreased by 1°C per hour during the successive 3 hour, but the max setting temperature decrease is 3°C.

(5) When the appliance operate with Sleep mode, the indoor fan run in the LOW setting, and the air flow direction same as the last setting and the temperature and air flow direction can be adjusted by user. The Running indicator will be flashed 10 times per 1 Hz frequency, then all the indicators turn OFF except the Sleep light after 5 min elapse. Those indicators will be recovery when the temperature or Time setting is adjusted, after the setting, the indicators will be lit in 10 sec, then turn OFF.

3-5 Automatic run (SMART) mode

When the appliance operates at the smart, the air flow direction can be adjusted.

(1) H/C appliance

a. When the setting temperature is 26°C, the appliance will be ran in the Cool if the room temperature exceeds 26°C.

b. When the room temperature exceeds 23°C, but below 26°C, it will be ran in the Dry mode(It will turn in Automatic setting After 3 min LOW air volume running.).

c. When the room temperature exceeds 21°C, but below 23°C, it will be operated in the Fan only, the air volume is set by LOW and the fan speed can be adjusted

d. When the room temperature is not more than 21°C, it will be operated in Heat mode, and the temperature is set to 22°C.

(2) Cool only appliance

a. When the room temperature exceeds 26°C, it will be ran in Cool mode, and the temperature is set to 26°C.

b. When the room temperature exceeds 23°C, but not more than 26°C, it will be operated in the Dry mode.

c. When the room temperature is not more than 23°C, it will be operated in the Fan only, the air volume is set to LOW and the fan speed can be adjusted

After the appliance start the smart operation, the setting temperature can be adjusted 2°C or 7°C (based on the remote mode)(the min accuracy is 1°C) up and down base on the automatic temperature setting, also the presetting temperature of PCB circuit.

In case of the specific operation selected, it could be re-select the other modes after the compressor ceased for 5 min or the setting temperature changed.

3-6 Cooling-run mode

3-6-1 Outdoor Fan

The outdoor fan's speeds except the single speed motor can be changed according to outdoor ambient temperatures.

When operating at a fixed frequency, the outdoor fan is forced to operate at the high speed.

3-6-2 Indoor fan operation

(1) When the indoor fan keep in running condition, this operation state could be controlled by the remote control with High, Median, Low and Automatic setting.

(2) When the appliance is set Automatic condition in the Cool mode for the first time, the fan speed will run at Low setting. After that, temperature and fan speed is shown as following.

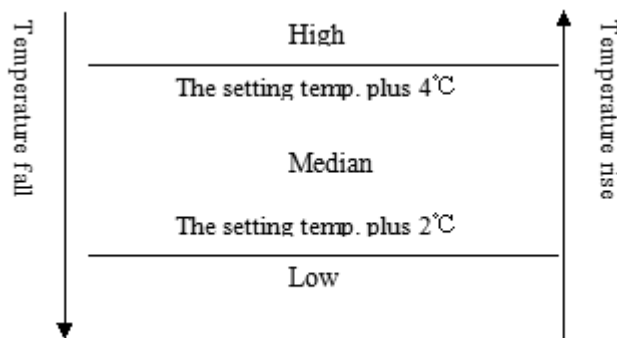

When the difference between the setting temperature and the room temperature equal to 2°C or 4°C, the indoor fan speed will keep in current speed.

3-6-3 Air flow direction control

The louver is derived by a step motor, and it swings the horizontal louver automatically. Press the SWING button to swing or stop the louver.

During the louver swing in normal operation, the current position will be stored. When the appliance turn off and louver swing automatically to the default position, it will position at the close position plus 5°.

3-6-4 4-way valve

State: It is interrupted in cooling.

Switchover: When initially powered on for cooling, the 4-way valve is interrupted immediately.

When the heating is changed to the cooling, it needs an interval of 50 seconds for the 4-way valve to change over from being activated to being interrupted.

3-7 Heating-run mode

3-7-1 Temperature compensation

The temperature compensation is 5° in heating mode. For example, if the set temperature is 25°C by the remote control, when the room temperature is detected with 31°C, the compressor will turn off. The main reason is that the hot air is condensed at the top of the house.

Note: The compensation is available only if the room temperature sensor of indoor unit is used and it is not available when it is subject to the sensor on the remote control.

3-7-2 Indoor fan motor operation

Anti-cold air system:

When the appliance run in Heat mode condition, the indoor fan motor operation is shown as following to prevent the cooling air come out during the appliance operation.

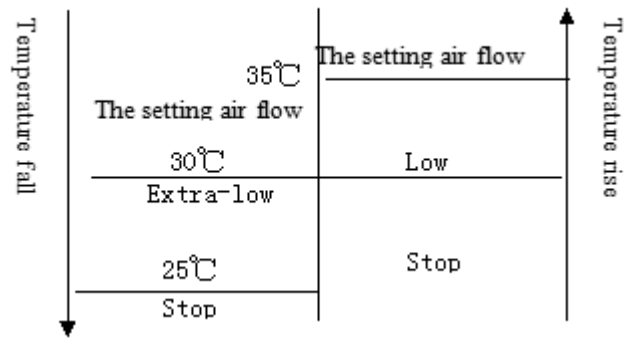

When the appliance turn in the anti-cold air system in the Extra-LOW (Tapped motor set in LOW, sic passim) during the compressor operation, the louver swang to the Cool air protection position, the louver recovers to the original position after the air volume change to LOW. When the room temperature reach to the setting temperature, the compressor will be turn off, and the air flow change to LOW, the louver swang to the Cool air protective position to prevent the air drop into human body directly; when the indoor pipe coil temperature drop continuously, it will turn in the Cooling air protective system in the Extra-LOW or stop the fan motor.

The indoor fan motor is only controlled by the signal of indoor pipe coil temperature, no matter the compressor turn ON/OFF, even the appliance turn in Heat mode at first time.

The indoor fan motor will operate according to the different setting(High, Median, Low and Automatic) by the remote control, but the anti-cold air system is prior.

When the appliance run in the Heat mode with the Automatic setting at first time, the fan speed will be in the LOW setting, and the operation diagram is shown as following

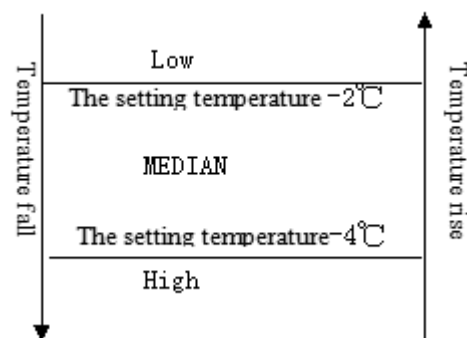

When the difference between the setting temperature and the room temperature equal to 2°C or 4°C, the indoor fan speed will keep in current speed.

3-7-3 Air flow direction control

The horizontal louver is controlled by a step motor, press the SWING button to swing or stop the louver.

During the louver run in normal operation, the current position will be stored. When the appliance turn off and louver swing automatically to the default position, it will position at the default

position plus 5°.

4-3-8-4 Outdoor fan

The outdoor fan speeds except single speed motor can be changed according to outdoor ambient temperatures.

3-7-6 4-way valve

State: It is electrified in heating.

Switchover: When initially powered on for heating, the 4-way valve is activated immediately.

In the change from cooling to heating, it needs an interval of 50 seconds for the 4-way valve to change over from being interrupted to being activated.

3-8 The super function (option)

In cooling mode, when you press the SUPER button by remote control, the unit will operate for 15 minutes with the following setting:

- a. The set temperature is 16°C;
- b. The fan speed with highest speed;
- c. The compressor runs with high frequency.

3-9 Dehumidifying mode

The dehumidifying mode is illustrated as follows:

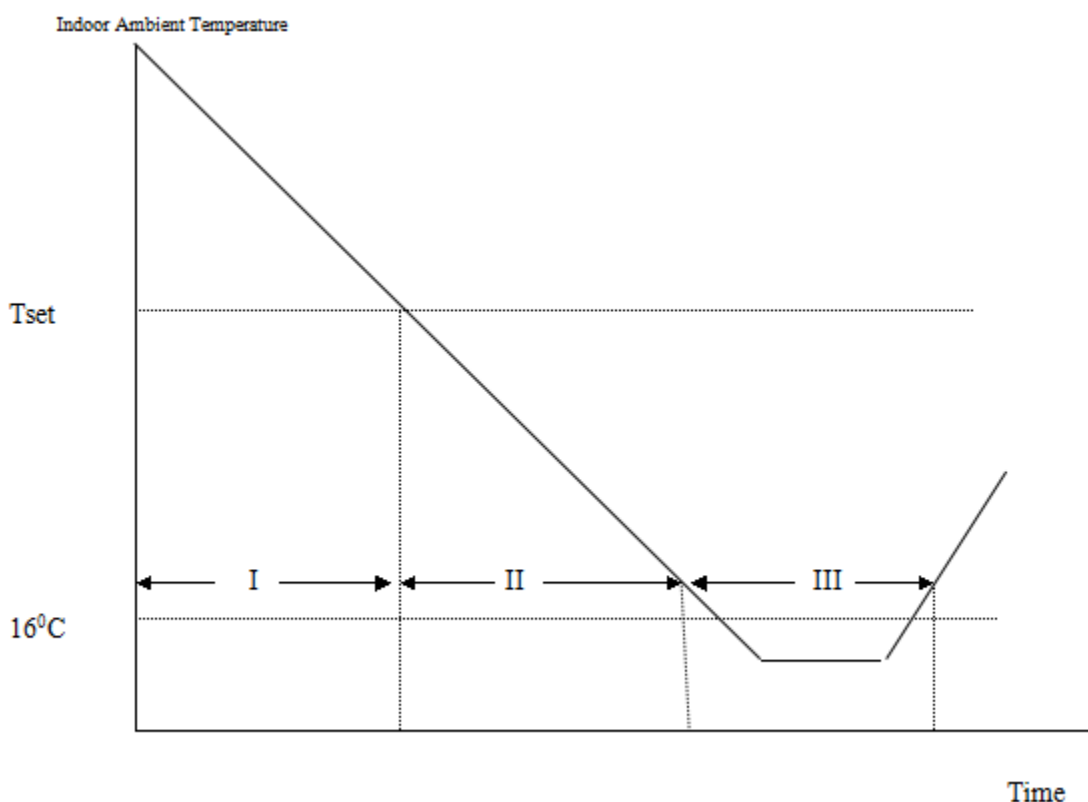

Dehumidifying area I: Operation at the frequency in the range (30–60Hz) according to Dt ($T_{indoor\ ambient} - T_{set}$).

Dt(°C)	f(Hz)
0	30

0.5	30
1	40
1.5	50
≥2	60

Dehumidifying area II: The compressor stops for 5 minutes and operators for 5 minutes at the lowest frequency.

Dehumidifying area III: The compressor stops.

3-10 Fan Only Mode Operation

During the appliance run in this mode, the compressor and outdoor fan stop, the indoor fan operate under the pre-setting of air volume, and the louver swing, and the indoor fan speed same as the Heating Mode.

5-3. Special Function Fnstruction

Conditions of anti-freezing prohibition of frequency rising:

Condition 1: in the case of anti-freezing frequency decreasing, the temperature of indoor heat exchanger rises to “anti-freezing frequency decreasing temperature”.

Condition 2: in normal operation, the temperature of indoor heat exchanger reaches “anti-freezing prohibition of frequency rising temperature”.

Either of the above two conditions is met, the product will enter anti-freezing prohibition of frequency rising state.

Anti-freezing prohibition of frequency rising operation: the compressor is kept at the current frequency, which may decrease according to situations while cannot rise. The outdoor fan runs.

Condition for the end of anti-freezing prohibition of frequency rising state: when the temperature of indoor heat exchanger rises to “anti-freezing releasing temperature”, the state of anti-freezing prohibition of frequency rising is released.

Conditions for defrosting:

A: When the heating compressor consecutively runs for 40 minutes (EEPROM setting value at the current operating mode);

B: If the ambient temperature minus the temperature of coiled pipe is equal to or higher than six degrees centigrade (EEPROM setting value in the current operating mode);

C: If the temperature of coiled pipe is equal to or lower than minus two degrees centigrade (EEPROM setting value in the current operating mode);

If the above three conditions are met simultaneously, defrosting begins.

Defrosting actions:

The compressor stops, and the outdoor fan stops after delay of 30 seconds; in 50 seconds the four-way valve is power off; and in 10 seconds the compressor starts and runs at “defrosting frequency”.

Conditions for ending defrosting:

Defrosting is over if either of the below conditions is met.

A: The accumulated time of defrosting is longer than 12 minutes (EEPROM setting value in the current operating mode);

B: If the temperature of coiled pipe is equal to or higher than 14 degrees centigrade (EEPROM setting value in the current operating mode);

Actions of exiting the defrosting state:

The compressor stops, and 50 seconds later the four-way valve opens, and another 10 seconds later the compressor and outdoor fan restart and begin normal operation.

6. Electrical Characteristics

- 1、FM:FAN MOTOR POWER WIRES
- 2、FMF:FAN MOTOR FEEDBACK
- 3、FMC:FAN CAPACITOR
- 4、SEN:PIPE&ROOM TEMPERATURE SENSOR
- 5、SM:SWING MOTOR
- 6、OF:OUTDOOR FAN
- 7、VAL:VALVE
- 8、CP:COMPRESSOR
- 9、L:POWER L
- 10、N:POWER N
- 11、ON/OFF:EMERGENCY BOTTON
- 12、SI:SIGNAL
- 13、HP:HIGH PERSSURE SWITCH
- 14、TRS:TRANSFORMER

Indoor 7.9.12.18.24K

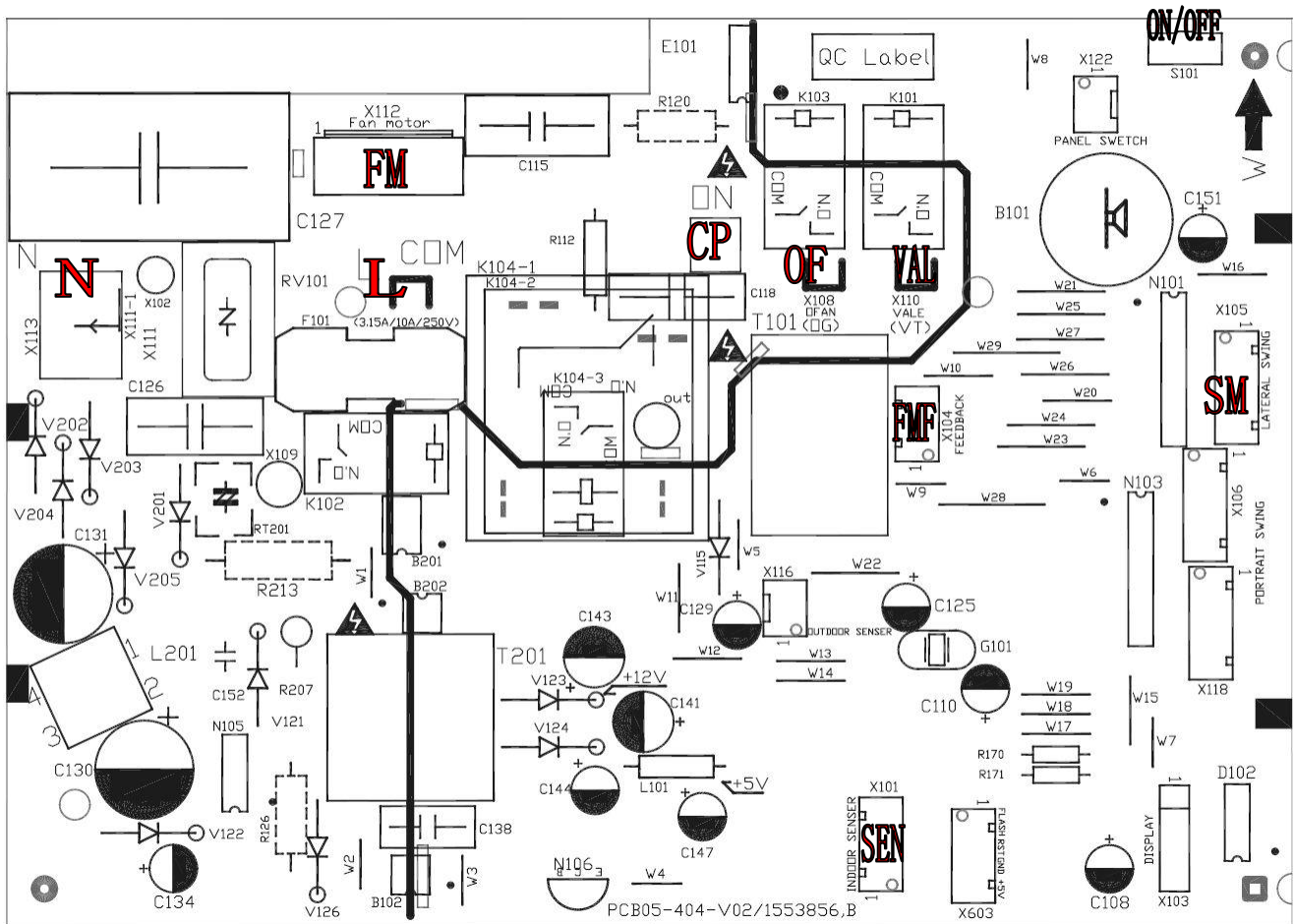

Indoor 30K

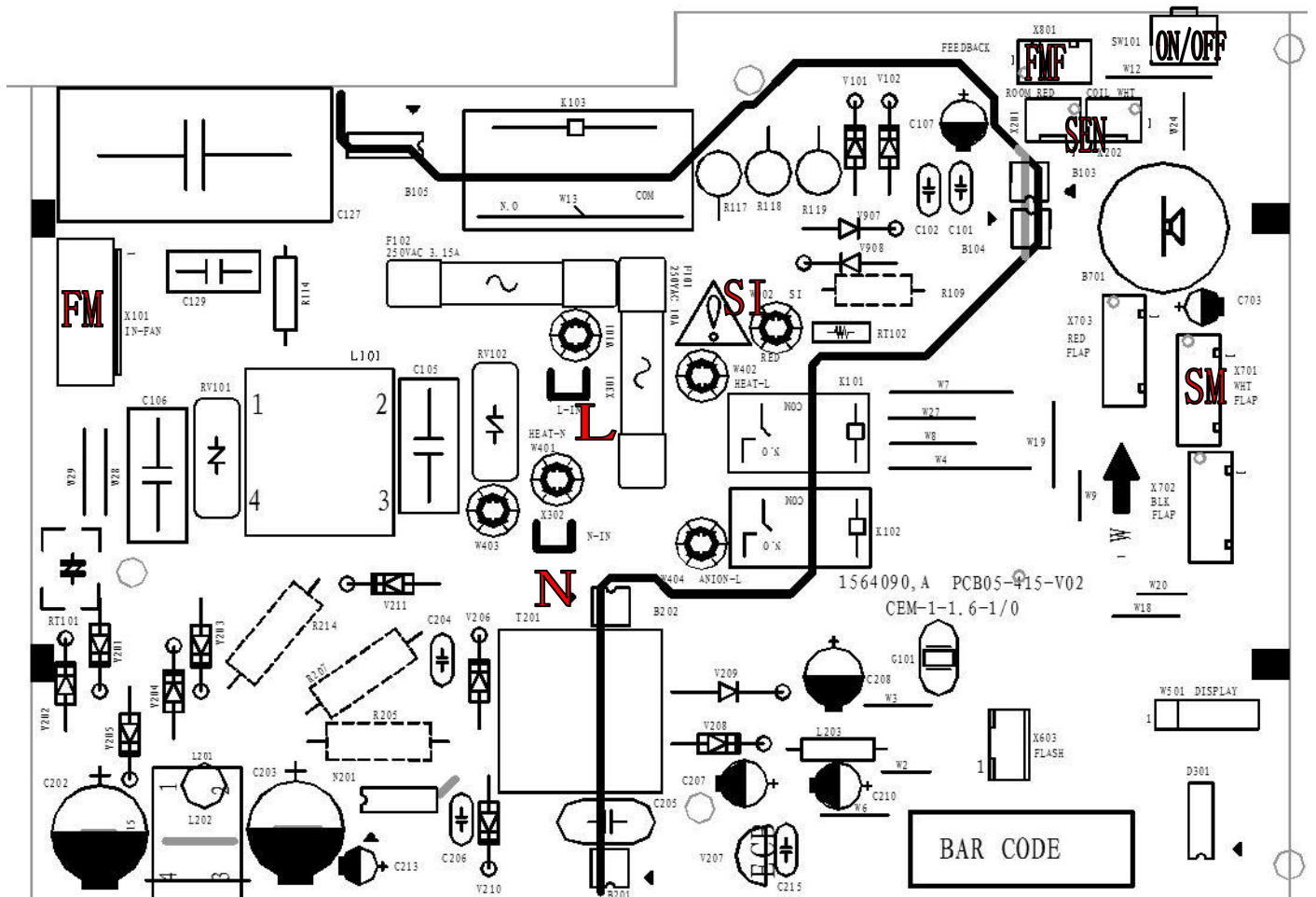

6-2. Fan Motor

Drawings attached:
INDOOR AC FAN

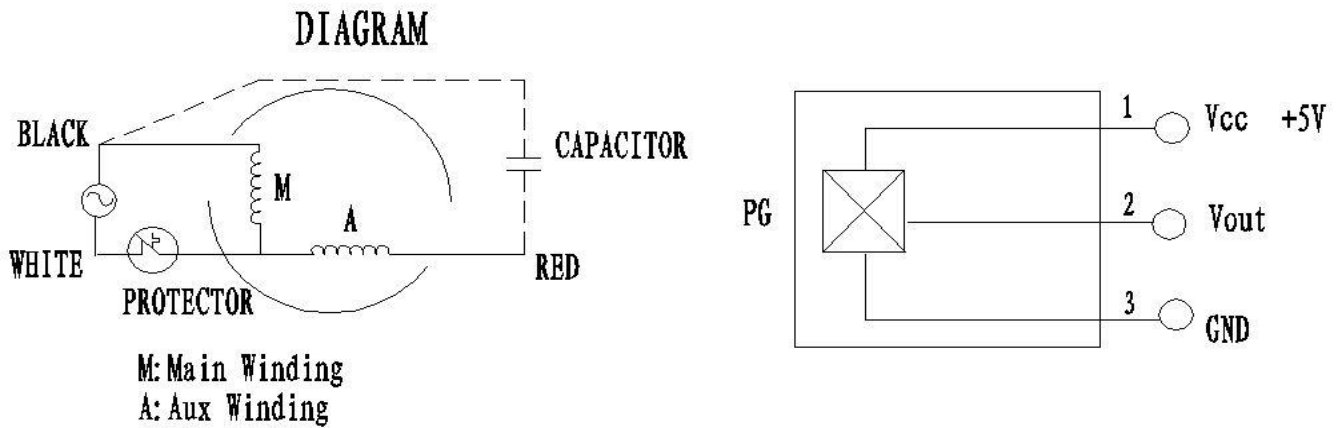

OUTDOOR AC FAN

DIAGRAM

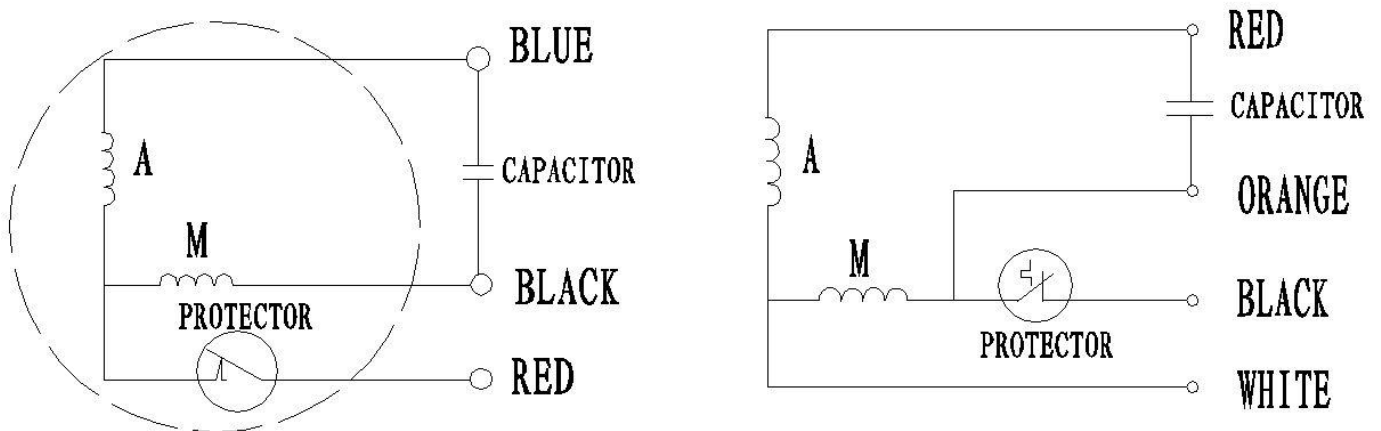

Test in resistance.

TOOL: Multimeter.

Test the resistance of the main winding. The indoor fan motor is fault if the resistance of main winding 0(short circuit)or ∞ (open circuit) .

Test in voltage

TOOL: Multimeter.

Insert screwdriver into to rotate indoor fan motor slowly for 1 revolution or over, and measure voltage "YELLOW" and "GND" on motor. The voltage repeat 0V DC and 5V DC.

Notes:

- 1) Please don't hold motor by lead wires.
- 2) Please don't plug IN/OUT the motor connecter while power ON.
- 3) Please don't drop hurl or dump motor against hard material. Malfunction may not be observed at early stage after such shock. But it may be found later, this type of mishandling void our warranty.

Indoor DC Fan Motor

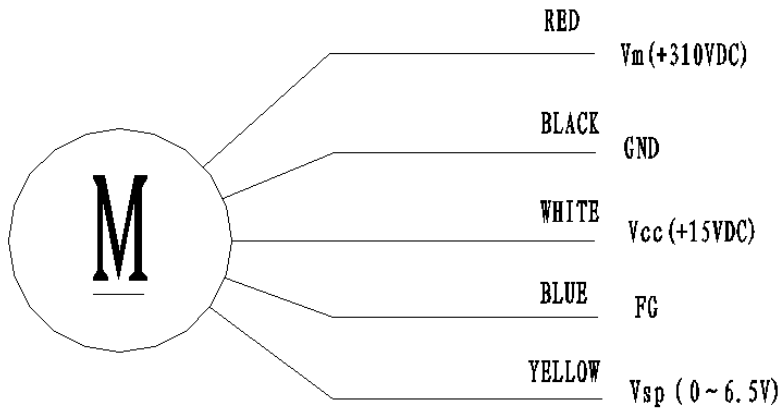

1	RED	$V_m(+310VDC)$
2	--	-----
3	--	-----
4	BLACK	GND
5	WHITE	$V_{cc}(+15VDC)$
6	BLUE	FG
7	YELLOW	$V_{sp}(0 \sim 6.5V)$

Outdoor DC Fan Motor

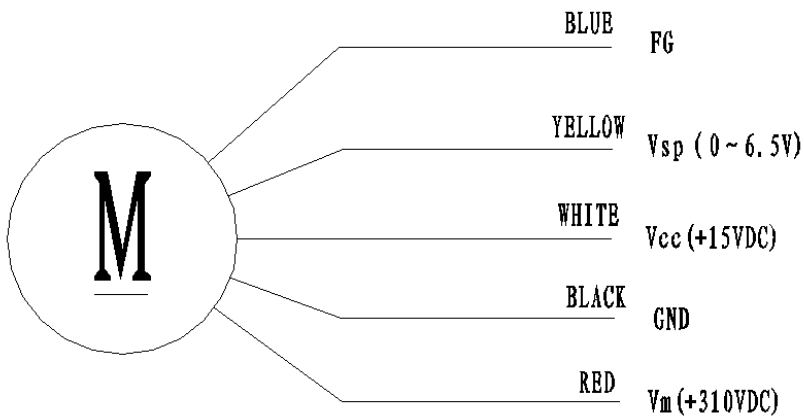

1	BLUE	FG
2	YELLOW	$V_{sp}(0 \sim 6.5V)$
3	WHITE	$V_{cc}(+15VDC)$
4	BLACK	GND
5	--	-----
6	RED	$V_m(+310VDC)$

6-3. Temperature Sensor

Parameter table attached:

THE PARAMETER OF THE INDOOR COIL AND INDOOR ROOM SENSOR
 (R(0)=15k B(0/100)=3450)

Model:AS-30HR4SQBDJ

Temperature(°C)	Resistance(k)	Voltage(V)		Temperature(°C)	Resistance(k)	Voltage(V)
-20	38.757	0.58143512		31	4.292	2.715076661
-19	36.844	0.60795346		32	4.137	2.76063657
-18	35.038	0.63530819		33	3.989	2.805589174
-17	33.331	0.66352684		34	3.847	2.850117358
-16	31.719	0.69257720		35	3.711	2.894109636
-15	30.196	0.72246147		36	3.58	2.937788018
-14	28.755	0.75321223		37	3.455	2.980713033
-13	27.392	0.78480857		38	3.335	3.023117961
-12	26.103	0.81722911		39	3.219	3.065272268
-11	24.882	0.85051031		40	3.108	3.106725146
-10	23.727	0.88458737		41	3.001	3.147759536
-9	22.632	0.91951536		42	2.899	3.187898487
-8	21.594	0.95527085		43	2.801	3.227439565
-7	20.611	0.99179340		44	2.706	3.266717909
-6	19.678	1.02913875		45	2.615	3.305249514
-5	18.794	1.06721353		46	2.528	3.342947037
-4	17.954	1.10609872		47	2.444	3.380169671
-3	17.158	1.14565549		48	2.363	3.416856492
-2	16.401	1.18599135		49	2.286	3.45247766
-1	15.683	1.22696435		50	2.211	3.487894953
0	15	1.26865672		51	2.139	3.522585993
1	14.351	1.31098658		52	2.07	3.556485356
2	13.734	1.35393437		53	2.003	3.590032381
3	13.148	1.39741342		54	1.939	3.622673675
4	12.589	1.44157386		55	1.877	3.654865988
5	12.058	1.48618720		56	1.818	3.686036427
6	11.553	1.53125563		57	1.76	3.717201166
7	11.071	1.57689691		58	1.705	3.747244673
8	10.613	1.62286005		59	1.652	3.776658768
9	10.176	1.66928515		60	1.6	3.805970149
10	9.76	1.71601615		61	1.551	3.834009923
11	9.363	1.76311968		62	1.503	3.861880963
12	8.985	1.81043663		63	1.457	3.888973616
13	8.624	1.85805887		64	1.413	3.91524643
14	8.279	1.90597205		65	1.37	3.941267388
15	7.951	1.95387327		66	1.328	3.967019291
16	7.637	2.00204130		67	1.289	3.991234935
17	7.337	2.05033368		68	1.25	4.015748031
18	7.051	2.09859271		69	1.213	4.039284017
19	6.778	2.14682606		70	1.177	4.062450215
20	6.516	2.19524793		71	1.142	4.085229093
21	6.267	2.24333597		72	1.109	4.106941536
22	6.028	2.29151689		73	1.076	4.12888601

23	5.8	2.33944954		74	1.045	4.149715216
24	5.581	2.38741691		75	1.015	4.17007359
25	5.372	2.43506494		76	0.986	4.189944134
26	5.172	2.48247664		77	0.957	4.210004953
27	4.981	2.52951096		78	0.93	4.228855721
28	4.797	2.57653834		79	0.904	4.247168554
29	4.622	2.62291710		80	0.878	4.265640683
30	4.453	2.66931854				

Note: the AD value in the table is calculated on the basis of the pull-down resistor is 5.1K.

(R(25)=15k B(25/50)=3950)

Model:7.9.12.18.24

Temperature(°C)	Resistance(k)	Voltage(V)	A/D
-20	152.5	4.5522388	E8
-19	143.9	4.528005	E7
-18	135.8	4.5026525	E6
-17	128.3	4.4766225	E4
-16	121.1	4.4489346	E3
-15	114.5	4.4208494	E1
-14	108.2	4.3912338	E0
-13	102.3	4.3606138	DE
-12	96.73	4.3287389	DD
-11	91.51	4.2958408	DB
-10	86	4.2574257	D9
-9	81.97	4.2265649	D8
-8	77.62	4.1902397	D6
-7	73.52	4.1527338	D4
-6	69.05	4.107674	D1
-5	66.01	4.0741884	D0
-4	62.58	4.033256	CE
-3	58.34	3.9773657	CB
-2	56.29	3.947959	C9
-1	53.41	3.9036691	C7
0	50.69	3.8582737	C5
1	48.12	3.8117871	C2
2	45.7	3.7644152	C0
3	43.41	3.7159733	BE
4	41.25	3.6666667	BB
5	39.2	3.6162362	B8
6	37.27	3.5651425	B6
7	35.44	3.5130849	B3
8	33.71	3.4602751	B0
9	32.08	3.4069669	AE
10	30.63	3.3563445	AB
11	29.06	3.2977758	A8
12	27.68	3.2427366	A5
13	26.36	3.1866538	A3
14	25.12	3.1306082	A0
15	23.84	3.069001	9D
16	22.82	3.0169223	9A
17	21.76	2.9597388	97
18	20.75	2.9020979	94
19	19.79	2.8442081	91
20	18.88	2.7863046	8E
21	18.03	2.729337	8B
22	17.21	2.6715306	88
23	16.44	2.6145038	85
24	15.7	2.5570033	82

Temperature(°C)	Resistance(k)	Voltage(V)	A/D
30	11.99	2.221193	71
31	11.47	2.1666037	6E
32	10.98	2.113164	6C
33	10.51	2.0599765	69
34	10.06	2.0071828	66
35	9.634	1.9554275	64
36	9.229	1.9045359	61
37	8.842	1.8542907	5F
38	8.474	1.8049757	5C
39	8.123	1.7564762	5A
40	7.789	1.7089385	57
41	7.47	1.6622163	55
42	7.165	1.6162869	52
43	6.875	1.5714286	50
44	6.597	1.5272955	4E
45	6.333	1.4843201	4C
46	6.08	1.4421252	4A
47	5.838	1.4008062	47
48	5.608	1.3606366	45
49	5.387	1.3211851	43
50	5.177	1.2828964	41
51	4.976	1.2454946	40
52	4.783	1.2088662	3E
53	4.599	1.1732741	3C
54	4.423	1.1385986	3A
55	4.255	1.1049078	38
56	4.093	1.0718588	37
57	3.939	1.0399176	35
58	3.792	1.00894	33
59	3.65	0.9785523	32
60	3.515	0.9492304	30
61	3.385	0.9205874	2F
62	3.261	0.8928865	2E
63	3.142	0.8659464	2C
64	3.028	0.8398047	2B
65	2.918	0.814265	2A
66	2.813	0.7895919	28
67	2.713	0.7658217	27
68	2.618	0.7429901	26
69	2.524	0.7201552	25
70	2.436	0.6985547	24
71	2.36	0.6797235	23
72	2.268	0.656706	21
73	2.189	0.6367444	20
74	2.114	0.617623	1F

25	15	2.5	80
26	14.33	2.4428912	7D
27	13.7	2.3867596	7A
28	13.1	2.3309609	77
29	12.53	2.2756992	74

75	2.041	0.5988498	1F
76	1.971	0.5806965	1E
77	1.905	0.5634428	1D
78	1.84	0.5463183	1C
79	1.778	0.5298605	1B
80	1.719	0.5140858	1A

7.Trouble Shooting

7-1. Error Code Table

7.1 The LED of indoor display board will show the error sequence automatically when the unit has the following trouble.

Error code	Remark: ★Light o Flash x OFF		
	Content	Remark	The root cause is may be one of the following
E2	When the evaporator pipe temperature is higher than 63 ℃, the error code will display		a. It is normally for protection, When the indoor pipe temperature between $53^{\circ}\text{C} < T < 63^{\circ}\text{C}$, the outdoor fan motor will stop running. When the indoor coil temperature is higher than 63°C , the error code will display. After the indoor pipe temperature is lower than 49°C , the air conditioner will restart normally. b. The indoor coil temperature sensor is loose; c. The indoor coil temperature sensor is failure; d. The indoor control board is failure.
E4	When the indoor fan speed is lower than 200 rpm, the error code will display		a. There are something block the indoor fan motor; b. The fan motor cord connect loose; c. The fan motor is failure; d. The indoor control board is failure
EA	the error code will display when the communication between display board and control board have in trouble		a. The connection between the display board and control board is loose; b. The indoor control board is failure. c. The wiring of the display board is failure.

7.2.The Error inquiry should be operate in the stand-by state, keep 5 sec press and hold on the emergency button in the indoor unit, the LED of indoor display board will be shown in 10 sec, then the indoor display will recovery to the original. If two or more malfunction happened, each error sequence will be splayed alternatively. If the appliance could save information under no power condition, then LED can be quired as aforesaid with stand-by state after power resume.

NOTE: If the troubleshooting inquiry display by 7-segment tube, then the error code will be displayed, otherwise only the LED of the display board can show.

Error code	Remark: ★Light o Flash X OFF		
	Content	Remark	The root cause is may be one of the following
1	The failure for temperature sensor of outdoor coil	Heat pump	a. The outdoor temperature sensor loose; b. The outdoor temperature sensor is failure; c. The indoor control board is failure
20	The failure for outdoor DC motor		a. The motor cord connection loose b. The motor is invalid c. The outdoor fan is blocked d. The outdoor control board is invalid

27	High or Low pressure protection for outdoor unit		<ul style="list-style-type: none"> a. The pressure switch is working b. The pressure switch is invalid c. The outdoor control board is invalid
33	The failure for temperature sensor of indoor room		<ul style="list-style-type: none"> a. The indoor room temperature sensor loose; b. The indoor room temperature sensor is failure; c. The indoor control board is failure.
34	The failure for temperature sensor of indoor coil temperature		<ul style="list-style-type: none"> a. The indoor coil temperature sensor loose; b. The indoor coil temperature sensor is failure; c. The indoor control board is failure.
36	The failure for communication of indoor and outdoor units		<ul style="list-style-type: none"> a. The interconnection cord loose b. The interconnection cord is not in proper order c. The indoor control board is invalid d. The outdoor control board is invalid
38	Indoor EEPROM failure		<ul style="list-style-type: none"> a. The EEPROM chip loose; b. The indoor control board is failure
39	Indoor fan motor run abnormally		<ul style="list-style-type: none"> a. There are something block the indoor fan motor; b. The fan motor cord connect loose; c. The fan motor is failure; d. The indoor control board is failure
41	The failure for Indoor grounding protective		The indoor control board is failure
42	Overcooling protection		<ul style="list-style-type: none"> a. It is normally for protection, When the indoor pipe temperature below $T < -1^{\circ}\text{C} (-7^{\circ}\text{C})$. Outdoor fan motor and compressor will stop running. When the Indoor pipe temperature is higher than $-1(-7^{\circ}\text{C})$, the unit will restart normally b. The indoor coil temperature sensor is loose; c. The indoor coil temperature sensor is failure; d. The indoor control board is failure.
43	Overheating protection		<ul style="list-style-type: none"> a. It is normally for protection, When the indoor pipe temperature between $53^{\circ}\text{C} < T < 63^{\circ}\text{C}$, the outdoor fan motor will stop running. When the indoor coil temperature is higher than 63°C, the error code will display. After the indoor pipe temperature is lower than 49°C, the air conditioner will restart normally. b. The indoor coil temperature sensor is loose; c. The indoor coil temperature sensor is failure; d. The indoor control board is failure.

Remark:

The failure is detected when the room temperature sensor broken or shorted over 5 sec.

The failure is detected when the temperature sensor of heater exchange broken or shorted over 5 sec.

The failure is detected when each setting data is not match after the EEPROM self-check two times.

The failure is occur when the grounding signal is not detected after the appliance power ON.

AS-07HR4SYDDJ
 AS-09HR4SYDDJ3
 AS-12HR4SVDDJ1

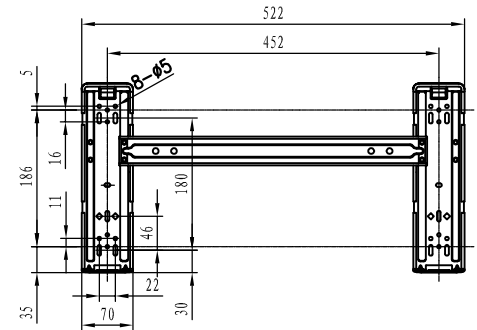
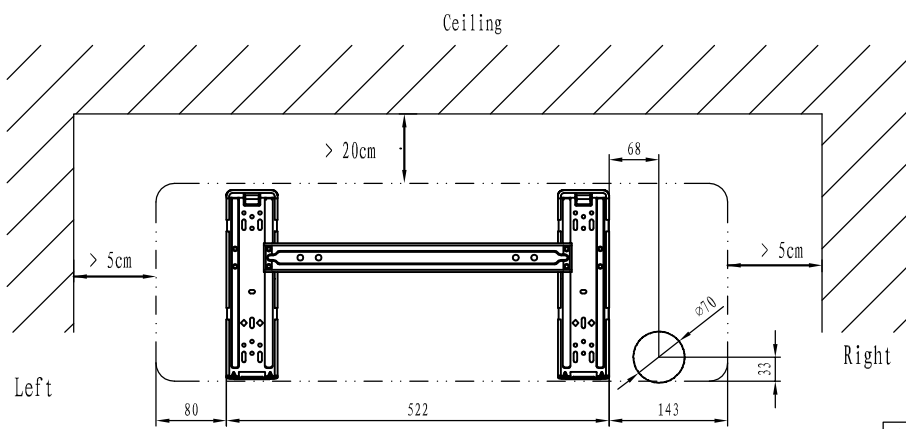
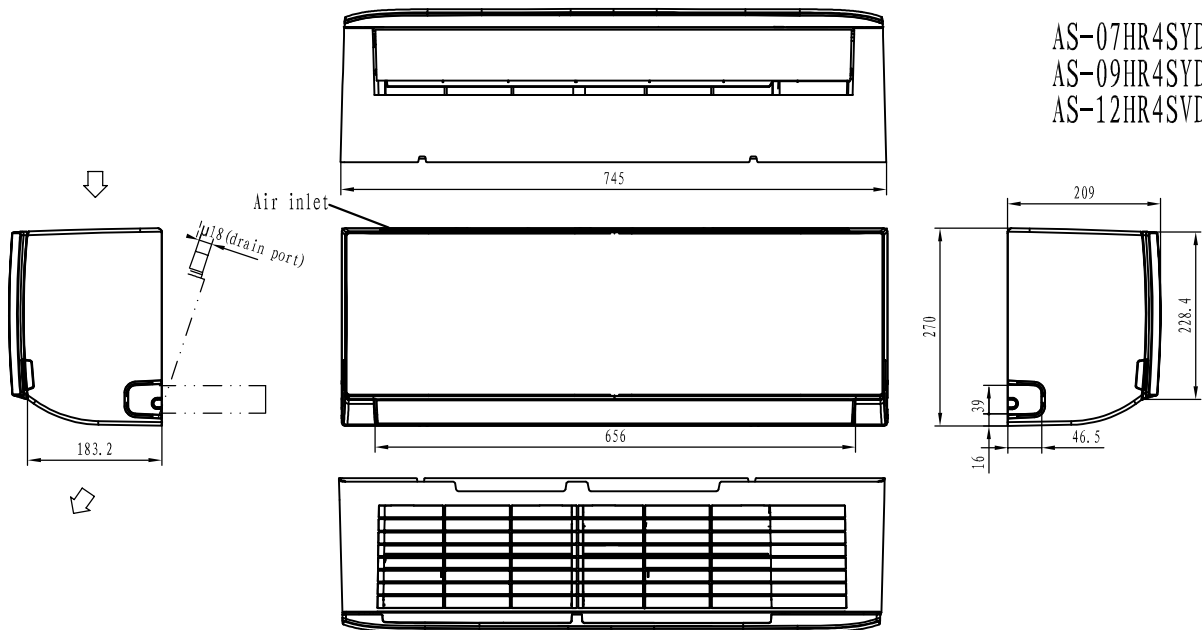

AS-07HR4SYDDJ	Liquid Side (Φ6.35mm)
AS-09HR4SYDDJ3	Gas Side (Φ9.53mm)
AS-12HR4SVDDJ1	Liquid Side (Φ6.35mm)
	Gas Side (Φ12.7mm)

AS-07HR4SYDDJ
 AS-09HR4SYDDJ3

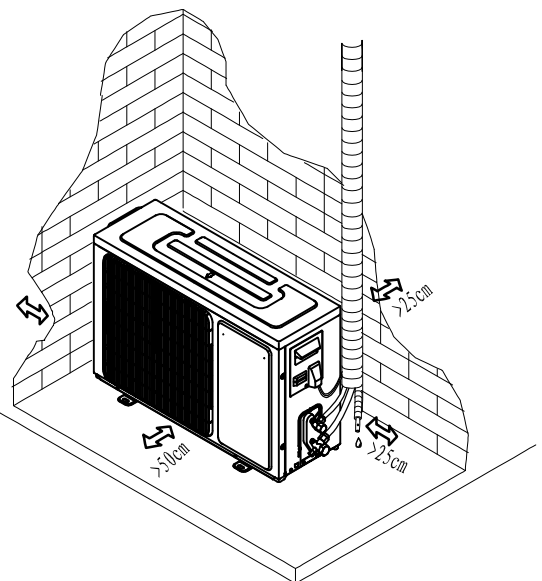
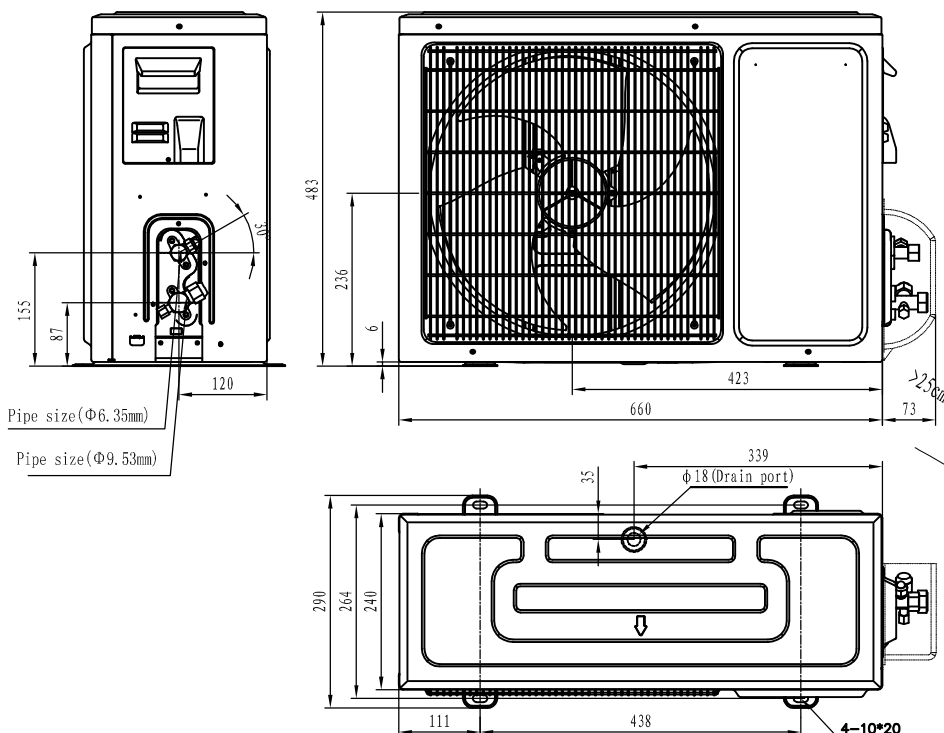

AS-07HR4SYDDJ	Refrigerant (R410A)
AS-09HR4SYDDJ3	

AS-12HR4SVDDJ1

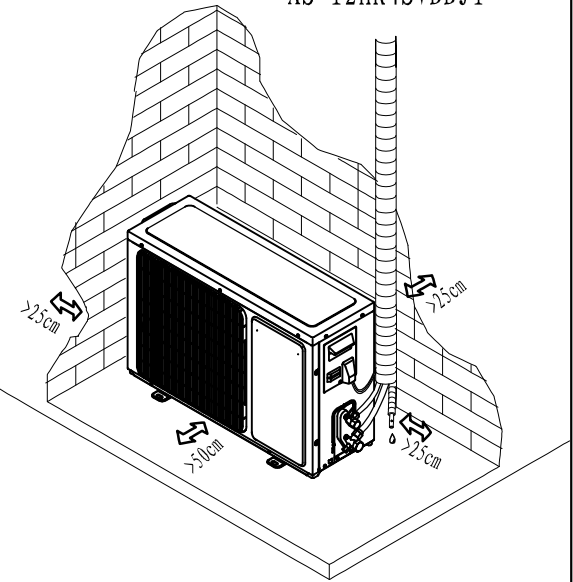
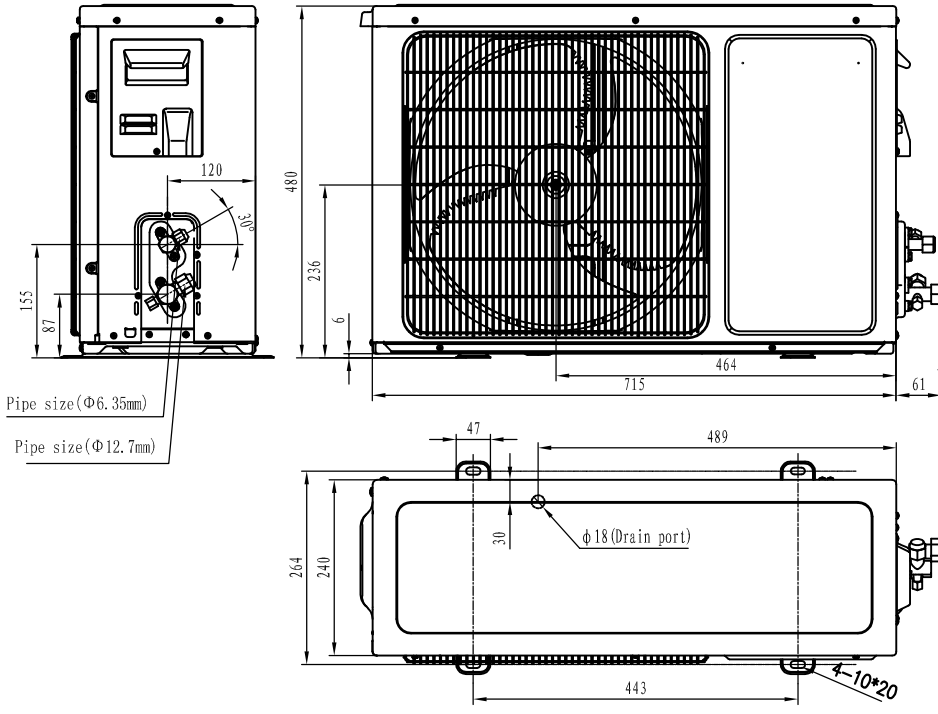

AS-12HR4SVDDJ1 Refrigerant (R410A)

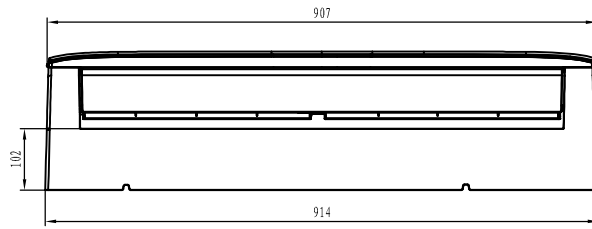

AS-18HR4SWADJ

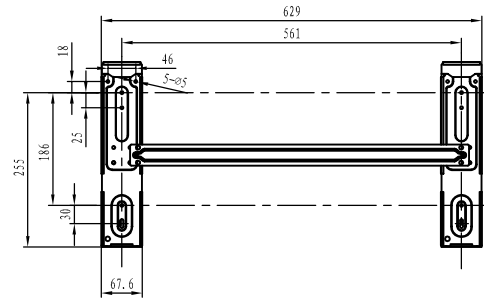
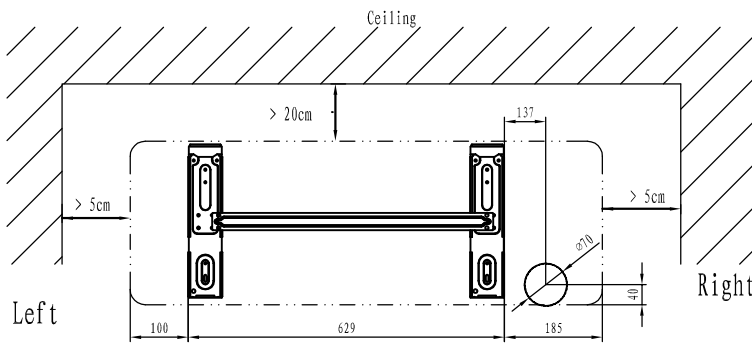
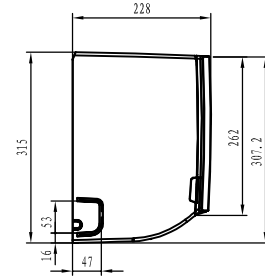
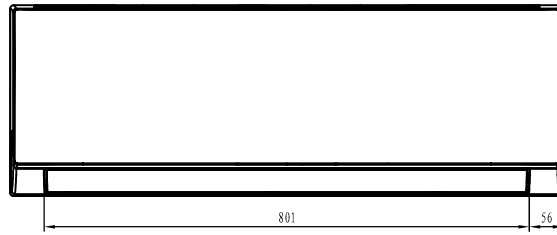
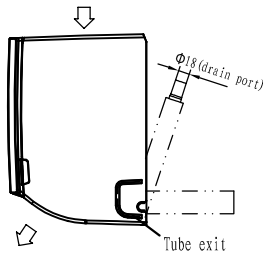

AS-18HR4SWADJ Liquid Side (Φ6.35mm)
Gas Side (Φ12.7mm)

AS-18HR4SWADJ

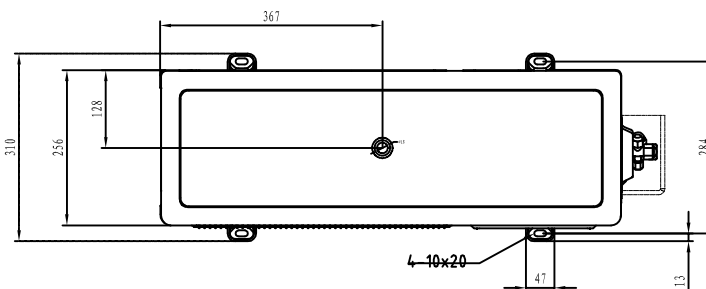
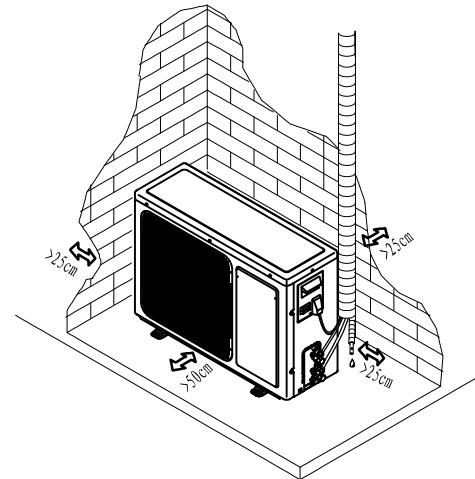
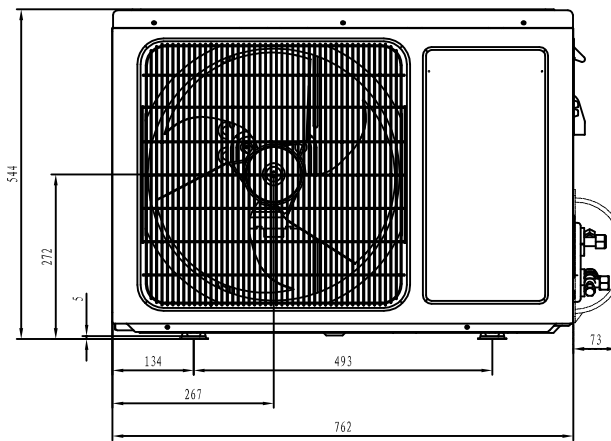
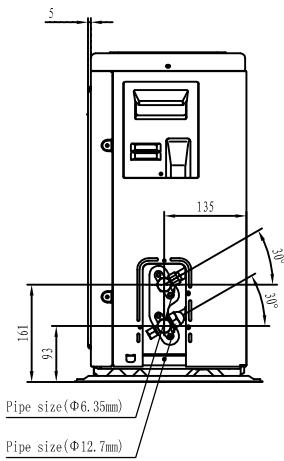

AS-18HR4SWADJ Refrigerant (R410A)

AS-24HR4SFADJ

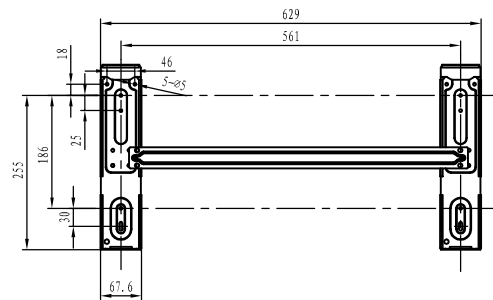
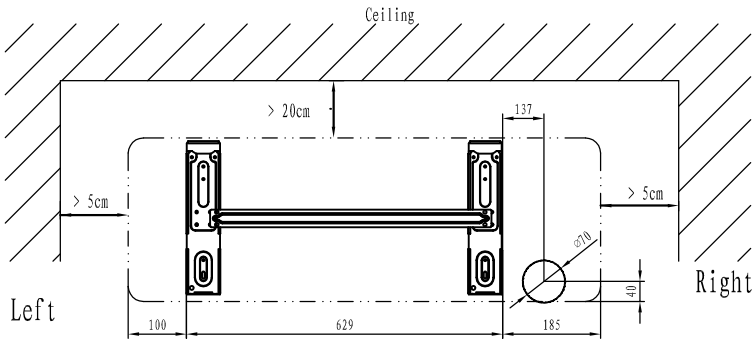
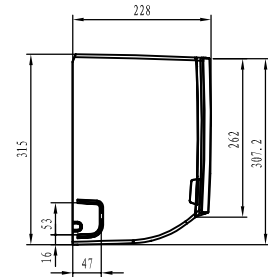
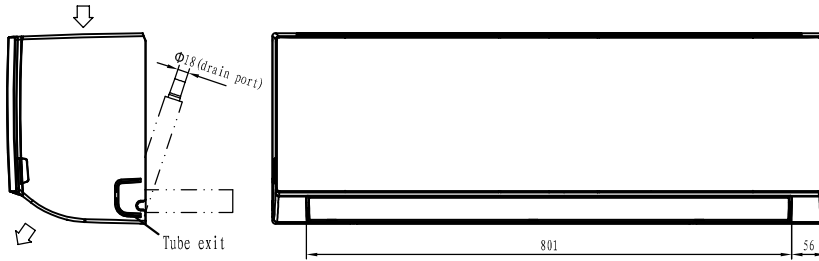
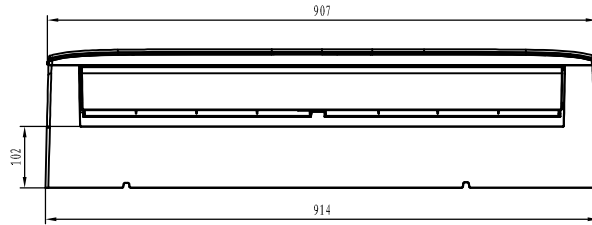

AS-24HR4SFADJ	Liquid Side (Φ9.53mm)
	Gas Side (Φ15.88mm)

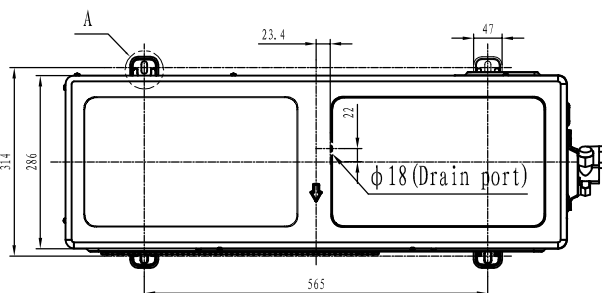
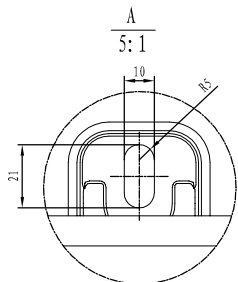
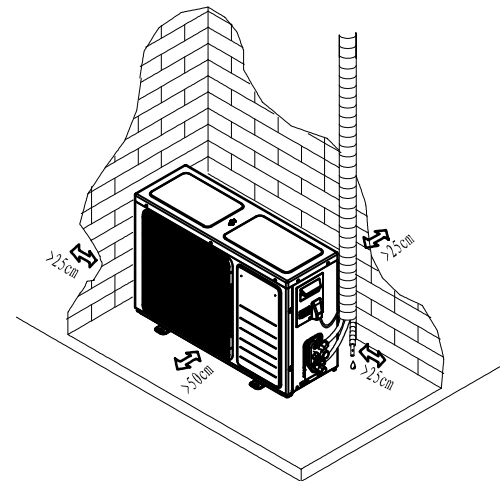
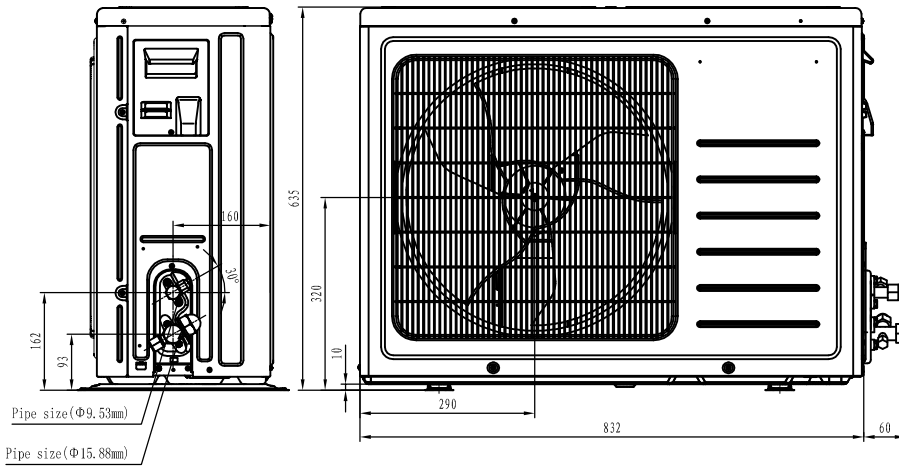

AS-24HR4SFADJ Refrigerant (R410A)

AS-30HR4SQBDJ

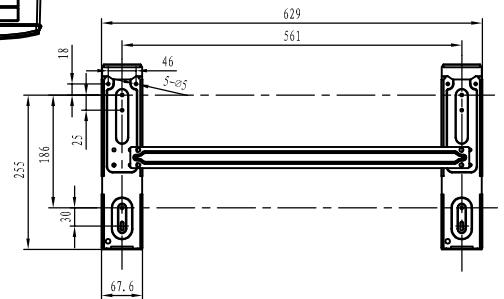
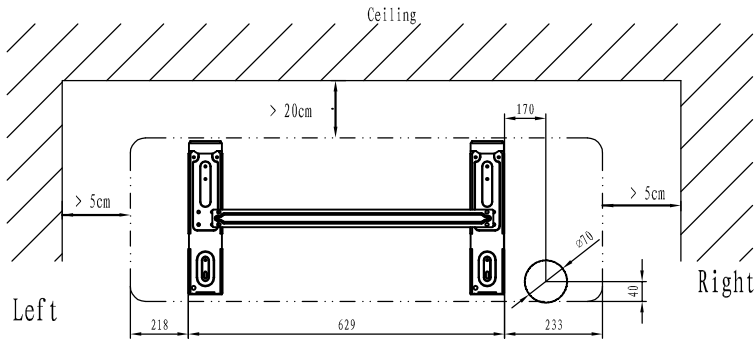
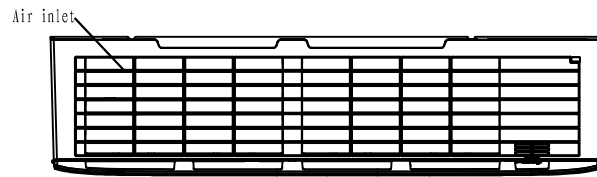
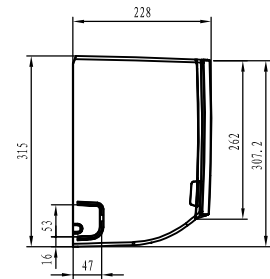
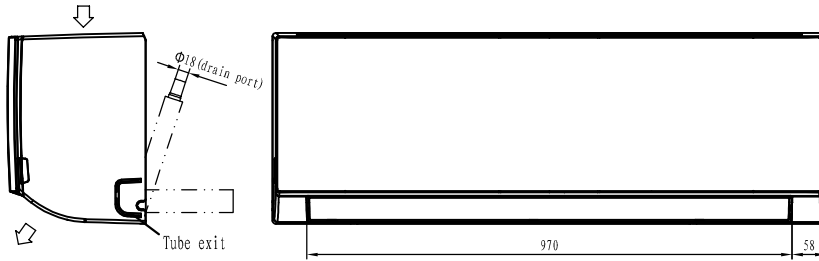
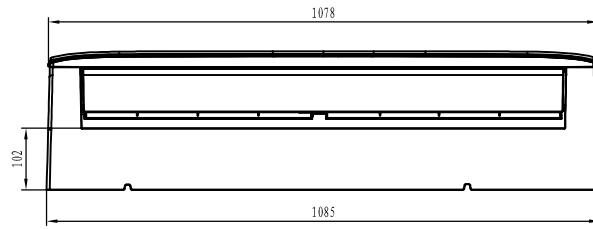

AS-30HR4SQBDJ	Liquid Side (Φ9.53mm)
	Gas Side (Φ15.88mm)

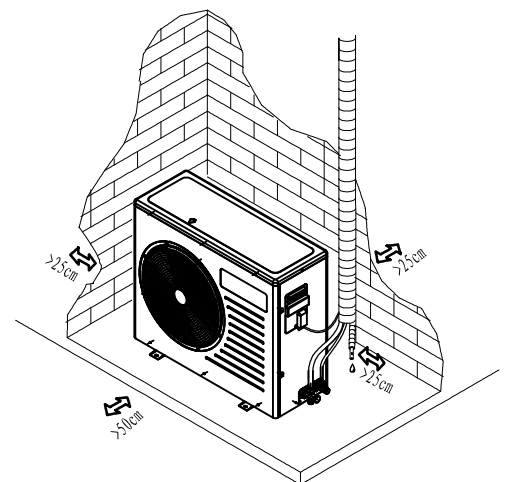
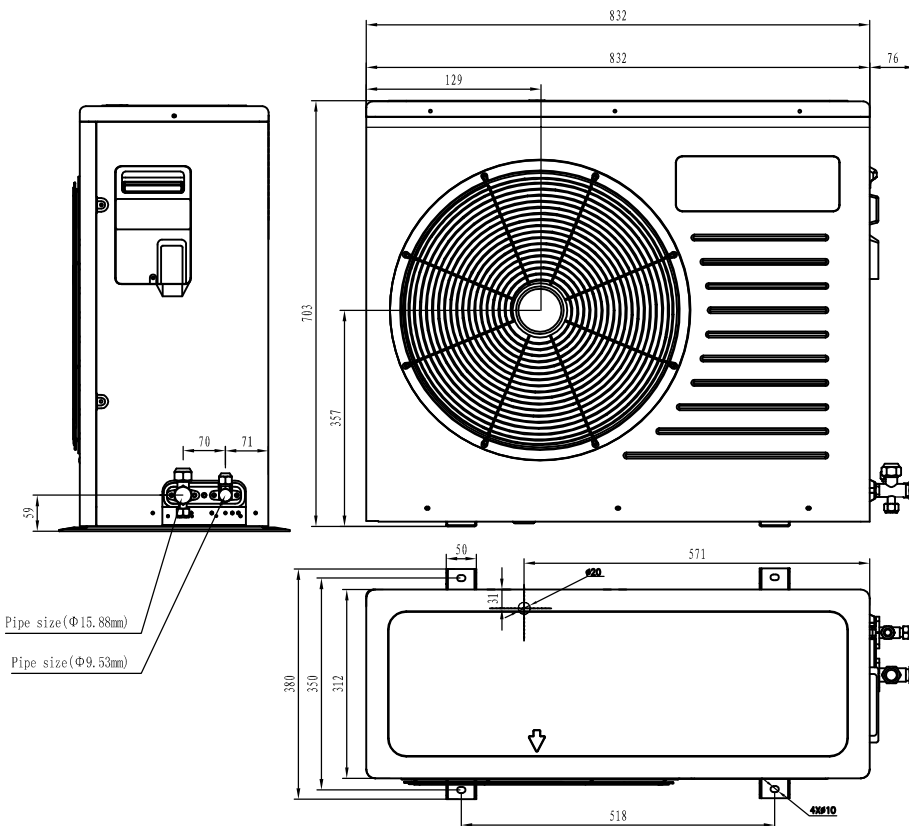

AS-30HR4SQBDJ | Refrigerant (R410A)

